



Commercial Series CM Radios

**UHF2 (438-470MHz) High Power
Service Information**

Computer Software Copyrights

The Motorola products described in this manual may include copyrighted Motorola computer programs stored in semiconductor memories or other media. Laws in the United States and other countries preserve for Motorola certain exclusive rights for copyrighted computer programs, including the exclusive right to copy or reproduce in any form, the copyrighted computer program. Accordingly, any copyrighted Motorola computer programs contained in the Motorola products described in this manual may not be copied or reproduced in any manner without the express written permission of Motorola. Furthermore, the purchase of Motorola products shall not be deemed to grant, either directly or by implication, estoppel or otherwise, any license under the copyrights, patents or patent applications of Motorola, except for the normal non-exclusive royalty-free license to use that arises by operation of law in the sale of a product.

Table of Contents

Chapter 1 MODEL CHART AND TECHNICAL SPECIFICATIONS

1.0 CM140/CM160 Model Chart	1-1
2.0 Technical Specifications	1-2

Chapter 2 THEORY OF OPERATION

1.0 Introduction	2-1
2.0 UHF (438-470MHz) Receiver	2-1
2.1 Receiver Front-End	2-1
2.2 Receiver Back End	2-2
3.0 UHF Transmitter Power Amplifier (438-470 MHz)	2-2
3.1 First Power Controller Stage	2-2
3.2 Power Controlled Driver Stage	2-3
3.3 Final Stage	2-3
3.4 Directional Coupler	2-3
3.5 Antenna Switch	2-3
3.6 Harmonic Filter	2-4
3.7 Power Control	2-4
4.0 UHF (438-470MHz) Frequency Synthesizer	2-4
4.1 Reference Oscillator	2-4
4.2 Fractional-N Synthesizer	2-5
4.3 Voltage Controlled Oscillator (VCO)	2-6
4.4 Synthesizer Operation	2-7
5.0 Controller Theory of Operation	2-8
5.1 Radio Power Distribution	2-8
5.2 Protection Devices	2-10
5.3 Automatic On/Off	2-10
5.4 Microprocessor Clock Synthesiser	2-11
5.5 Serial Peripheral Interface (SPI)	2-12
5.6 SBEP Serial Interface	2-12
5.7 General Purpose Input/Output	2-12
5.8 Normal Microprocessor Operation	2-13
5.9 Static Random Access Memory (SRAM)	2-14
6.0 Control Board Audio and Signalling Circuits	2-14
6.1 Audio Signalling Filter IC and Compander (ASFIC CMP)	2-14
7.0 Transmit Audio Circuits	2-15
7.1 Microphone Input Path	2-15
7.2 PTT Sensing and TX Audio Processing	2-16

8.0	Transmit Signalling Circuits	2-17
8.1	Sub-Audio Data (PL/DPL)	2-17
8.2	High Speed Data	2-18
8.3	Dual Tone Multiple Frequency (DTMF) Data	2-18
9.0	Receive Audio Circuits.....	2-19
9.1	Squelch Detect.....	2-19
9.2	Audio Processing and Digital Volume Control.....	2-20
9.3	Audio Amplification Speaker (+) Speaker (-).....	2-20
9.4	Handset Audio.....	2-21
9.5	Filtered Audio and Flat Audio	2-21
10.0	Receive Signalling Circuits	2-21
10.1	Sub-Audio Data (PL/DPL) and High Speed Data Decoder	2-21
10.2	Alert Tone Circuits.....	2-22

Chapter 3 TROUBLESHOOTING CHARTS

1.0	Troubleshooting Flow Chart for Receiver RF (Sheet 1 of 2).....	3-2
1.1	Troubleshooting Flow Chart for Receiver (Sheet 2 of 2)	3-3
2.0	Troubleshooting Flow Chart for 40W Transmitter (Sheet 1 of 3)	3-4
2.1	Troubleshooting Flow Chart for 40W Transmitter (Sheet 2 of 3).....	3-5
2.2	Troubleshooting Flow Chart for 40W Transmitter (Sheet 3 of 3).....	3-6
3.0	Troubleshooting Flow Chart for Synthesizer.....	3-7
4.0	Troubleshooting Flow Chart for VCO.....	3-8
5.0	Troubleshooting Flow Chart for DC Supply (1 of 2).....	3-9
5.1	Troubleshooting Flow Chart for DC Supply (2 of 2)	3-10

Chapter 4 UHF2 PCB/ SCHEMATICS/ PARTS LISTS

1.0	Allocation of Schematics and Circuit Boards	4-1
1.1	UHF2 and Controller Circuits	4-1
2.0	UHF2 25-40W PCB 8486577Z01 / Schematics.....	4-3
2.1	UHF2 PCB 8486577Z01 Parts List 40W	4-19

MODEL CHART AND TECHNICAL SPECIFICATIONS

1.0 CM140/CM160 Model Chart

CM Series, UHF2, 438-470 MHz			
Model		Description	
MDM50RPC9AA2		CM140 438-470 MHz, 40W, 8CH, BNC	
MDM50RPF9AA2		CM160 438-470 MHz, 40W, 64CH, BNC	
	Item	Description	
X		PMUE2008_	CM140 Super Tanapa UHF2, 40W, 8CH, BNC
	X	PMUE2011_	CM160 Super Tanapa UHF2, 40W, 64CH, BNC
X		PMUE2033_	CM140 Tanapa UHF2, 40W, 8CH, BNC
	X	PMUE2035_	CM160 Tanapa UHF2, 40W, 64CH, BNC
X		FCN6288_	Control Head
	X	FCN5523_	Control Head
X		PMUE2033_S	CM140 UHF2 U/C BNC Service Board
	X	PMUE2035_S	CM160 UHF2 U/C BNC Service Board
X	X	RMN5018	Mag One Microphone
X	X	6866546D02_	RTTE Leaflet
X	X	6866537D37_	Safety Leaflet
X	X	GLN7324_	Low Profile Trunnion

x = Indicates one of each is required.

2.0 Technical Specifications

Data is specified for +25°C unless otherwise stated.

General	
Specification	UHF2
Frequency Range:	438-470 MHz
Frequency Stability (-30°C to +60°C, 25°C Ref.)	±2.5 PPM
Channel Capacity:	CM140 - 8 CM160 - 64
Channel Spacing:	12.5/25 kHz
Power Supply:	13.6 Vdc (10.88 Vdc - 16.32 Vdc) negative Vehicle ground
Dimensions (L x W x H)	118mm X 169.5mm X 44mm (4.65" X 6.67" X 1.73")
Weight	1.01 kg (2.22 lbs)
FCC Description	ABZ99FT4048
Operating Temperature	-30 to 60° C (Display only -20°C to 60°C)
Storage Temperature	-40 to 85° C
Thermal Shock	-40 to 80° C
High Humidity	95% RH @ 50° C for 8 hrs
ESD	15KV air discharge
Packing Test	Impact Test

Transmitter	
Specification	UHF2
Power Output	25-40W
Conducted/Radiated Emissions:	-36 dBm < 1 GHz -30 dBm > 1 GHz
Audio Response: (from 6 dB/oct. Pre-Emphasis, 300 to 3000Hz)	TIA603 and CEPT
Tx Audio Distortion	< 3%
Modulation Limiting:	±2.5 kHz @ 12.5 kHz ±4.0 kHz @ 20 kHz ±5.0 kHz @ 25 kHz
FM Hum and Noise:	-35 dB@12.5 kHz -40 dB@25 kHz

Receiver	
Specification	UHF2
Sensitivity (12 dB SINAD):	0.35 μV @ 12.5 kHz 0.3 μV @ 25 kHz
Intermodulation:	60 dB@12.5 kHz 70 dB@25 kHz
Adjacent Channel Selectivity:	60 dB @ 12.5 kHz 70 dB @ 25 kHz
Spurious Response	70 dB
Rated Audio Power	4 W (typ.) Internal 7.5 W @ 5 % External
Audio Distortion	< 5 %
Hum and Noise:	-35 dB @ 12.5 kHz -40 dB @ 25 kHz
Audio Response	TIA603 and CEPT
Conducted Spurious Emission per FCC Part 15:	-57 dBm <1 Ghz -47 dBm >1 Ghz

Specifications subject to change without notice. All electrical specifications and methods refer to EIA/TIA 603 standards.

THIS PAGE INTENTIONALLY LEFT BLANK

Chapter 2

THEORY OF OPERATION

1.0 Introduction

This Chapter provides a detailed theory of operation for the UHF circuits in the radio. Details of the theory of operation and trouble shooting for the the associated Controller circuits are included in this Section of the manual.

2.0 UHF (438-470MHz) Receiver

2.1 Receiver Front-End

The received signal is applied to the radio's antenna input connector and routed through the harmonic filter and antenna switch. The insertion loss of the harmonic filter/antenna switch is less than 1 dB. The signal is routed to the first filter (3-pole), which has an insertion loss of 2 dB typically. The output of the filter is matched to the base of the LNA (Q303) that provides a 16 dB gain and a noise figure of better than 2 dB. Current source Q301 is used to maintain the collector current of Q303. Diode CR301 protects Q303 by clamping excessive input signals. Q303 output is applied to the second filter (4-pole) which has an insertion loss of 1.5 dB. In Distance mode, Q304 turns on and causes D305 to conduct, thus bypassing C322 and R337. In Local mode, the signal is routed through C322 and R337, thus inserting 7 dB attenuation. Since the attenuator is located after the RF amplifier, the receiver sensitivity is reduced only by 6 dB, while the overall third order input intercept is raised.

The first mixer is a passive, double-balanced type, consisting of T300, T301 and U302. This mixer provides all of the necessary rejection of the half-IF spurious response. Low-side injection at +10 dBm is delivered to the first mixer. The mixer output is then connected to a duplex network which matches its output to the XTAL filter input (FL300) at the IF frequency of 44.85 MHz. The duplex network terminates into a 50 ohm resistor (R340) at all other frequencies.

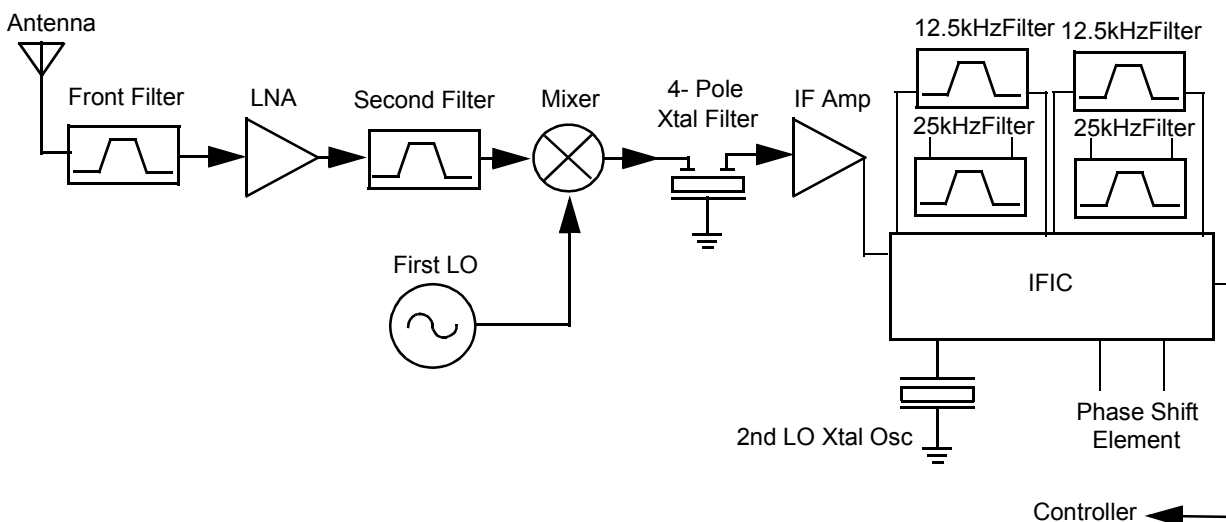

Figure 2-1 UHF Receiver Block Diagram

2.2 Receiver Back End

The IF signal from the crystal filter enters the IF amplifier which provides 20 dB of gain and feeds the IF IC at pin 1. The first IF signal at 44.85 MHz mixes with the second local oscillator (LO) at 44.395 MHz to produce the second IF at 455 kHz. The second LO uses the external crystal Y301. The second IF signal is amplified and filtered by two external ceramic filters (FL303/FL302 for 12.5KHz channel spacing and FL304/FL301 for 25KHz channel spacing). The IF IC demodulates the signal by means of a quadrature detector and feeds the detected audio (via pin 7) to the audio processing circuits. At IF IC pin 5, an RSSI signal is available with a dynamic range of 70 dB.

3.0 UHF Transmitter Power Amplifier (438-470 MHz)

The radio's 40W PA is a three-stage amplifier used to amplify the output from the VCOBIC to the radio transmit level. All three stages utilize LDMOS technology. The gain of the first stage (U101) is adjustable and controlled by pin 7 of U103-2 via U103-3. It is followed by an LDMOS stage Q105 and LDMOS final stage Q100.

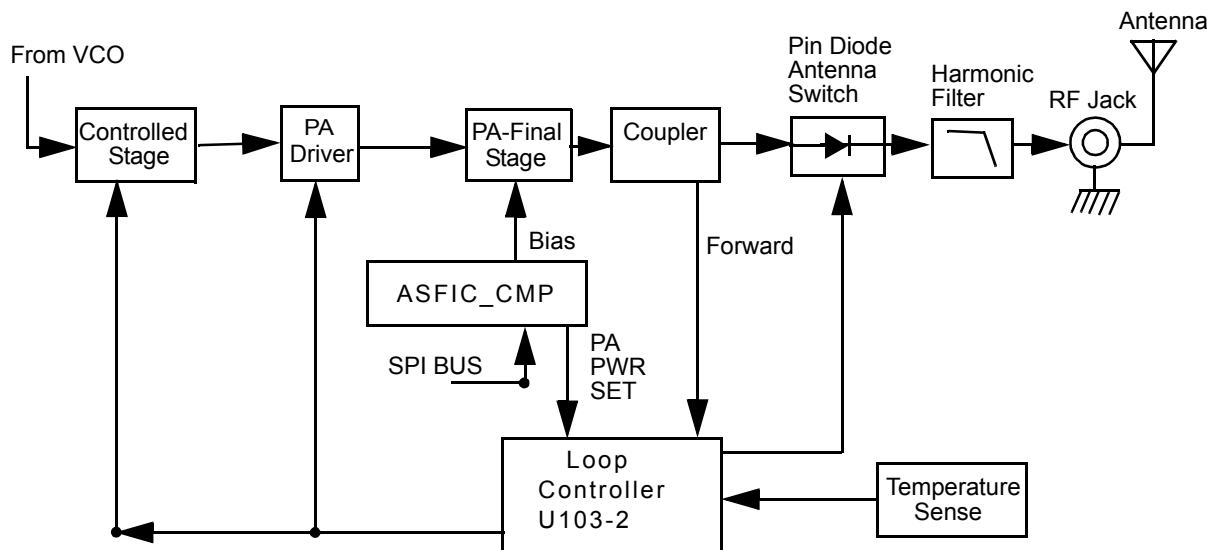

Figure 2-2 UHF Transmitter Block Diagram

Devices U101, Q105 and Q100 are surface mounted. Q100 is screwed down to the chassis to ensure good thermal contact. This scheme also ensures sufficient thermal contact between driver and chassis.

3.1 First Power Controller Stage

The first stage (U101) is a 24dB gain integrated circuit containing two LDMOS FET amplifier stages. It amplifies the RF signal from the VCO (TX_INJ). The output power of stage U101 is controlled by a DC voltage applied to pin 1 from the op-amp U103-3, pin 8. The control voltage simultaneously varies the bias of two FET stages within U101. This biasing point determines the overall gain of U101 and therefore its output drive level to Q105, which in turn controls the output power of the

PA.Op-amp U103-3 monitors the drain current of U101 via resistor R122 and adjusts the bias voltage of U101.

In receive mode, the DC voltage from RX_EN line turns on Q101, which in turn switches off the biasing voltage to U101.

3.2 Power Controlled Driver Stage

The next stage is an LDMOS device (Q105) which provides a gain of 12dB. This device requires a positive gate bias and a quiescent current flow for proper operation. The voltage of the PA_CURRENT is set in transmit mode by ASFIC (U504 pin 5) and fed to the gate of Q105 via resistive network R186, R187. This bias voltage is tuned in the factory. If the transistor is replaced, the bias voltage must be tuned using Global Tuner. Care must be taken so that the transistor is not tuned exceeding the allowed bias voltage. This device directly drains current from B+ via L122.

3.3 Final Stage

The final stage is an LDMOS device (Q100) providing a gain of 12dB. This device also requires a positive gate bias and a quiescent current flow for proper operation. The voltage of the line PA_BIAS is set in transmit mode by ASFIC (U504 pin 4) and fed to the gate of Q100 via the resistive network R134, R131. This bias voltage is tuned in the factory. If the transistor is replaced, the bias voltage must be tuned using the Global Tuner. Care must be taken not to damage the device by exceeding the maximum allowed bias voltage. The device's drain current is drawn directly from the radio's DC supply voltage input, B+, via L117, L115, L124 and L125.

A matching network consisting of C1005, C1017, C1004, C1009, C1008, C1007, C1274, C1279, C1275, C1276, C1277, C1278, C1021, C1280, C1013, L126, L127 and two striplines, transforms the impedance to 50 ohms and feeds the directional coupler.

3.4 Directional Coupler

The directional Coupler is a microstrip printed circuit, which couples a small amount of the forward power of the RF power from Q100. Coupled power is rectified by diode D105 to produce a proportional DC voltage; and the resulting DC voltage is routed to the power control section to ensure that the forward power out of the radio is held to a constant value.

3.5 Antenna Switch

The antenna switch utilizes the existing dc feed (B+) to the last stage device (Q100). The basic operation is to have both PIN diodes (D103, D104) turned on during key-up by forward biasing them. This is achieved by pulling down the voltage at the cathode end of D104 to around 12.4V (0.7V drop across each diode). The current through the diodes needs to be set around 100 mA to fully open the transmit path through resistor R108. Q106 is a current source controlled by Q103 which is turned on in Tx mode by TX_EN. VR102 ensures that the voltage at resistor R107 never exceeds 5.6V.

3.6 Harmonic Filter

Inductors L111, L113 and L128 along with capacitors C1011, C1023, C1020, C1016, C1025 and C1026 form a low-pass filter to attenuate harmonic energy coming from the transmitter. Resistor R150 along with L130 drains any electrostatic charges that might otherwise build up on the antenna. The harmonic filter also prevents high level RF signals above the receiver passband from reaching the receiver circuits to improve spurious response rejection.

3.7 Power Control

The output power is regulated by using a forward power detection control loop. A directional coupler samples a portion of the forward and reflected RF power. The forward sampled RF is rectified by diode D105, and the resulting DC voltage is routed to the operational amplifier U100. The error output current is then routed to an integrator, and converted into the control voltage. This voltage controls the bias of the pre-driver (U101) stage. The output power level is set by PWR_SET at ASFIC (U504 pin 6) which acts as the reference for forward power control loop.

The reflected coupled power is rectified by diode D107, The resulting DC voltage is amplified by an operational amplifier U100 and routed to the summing junction. This detector protects the final stage Q100 from reflected power by increasing the error current. The temperature sensor protects the final stage Q100 from overheating by increasing the error current. A thermistor RT100 measures the final stage Q100 temperature. The voltage divider output is routed to an operational amplifier U103 and then goes to the summing junction. The Zener Diode VR101 keeps the loop control voltage below 5.6V and eliminates the DC current from the 9.3 regulator U501.

One local loop for the Pre Driver (U101) is used in order to stabilize the current for each stage.

In Rx mode, the two transistors Q101 and Q102 go to saturation and shut down the transmitter by applying ground to the Pre Driver U101.

4.0 UHF (438-470MHz) Frequency Synthesizer

The synthesizer consists of a reference oscillator (Y201), low voltage Fractional-N (LVFRAC-N) synthesizer (U200), and a voltage controlled oscillator (VCO) (U201).

4.1 Reference Oscillator

The reference oscillator is a crystal (Y201) controlled Colpitts oscillator and has a frequency of 16.8MHz. The oscillator transistor and start-up circuit are located in the LVFRAC-N (U200) while the oscillator feedback capacitors, crystal, and tuning varactors are external. An analog-to-digital (A/D) converter internal to the LVFRAC-N (U200) and controlled by the microprocessor via SPI sets the voltage at the warp output of U200 pin 25. This sets the frequency of the oscillator. Consequently, the output of the crystal Y201 is applied to U200 pin 23.

The method of temperature compensation is to apply an inverse Bechmann voltage curve, which matches the crystal's Bechmann curve to a varactor that constantly shifts the oscillator back on frequency. The crystal vendor characterizes the crystal over a specified temperature range and codes this information into a bar code that is printed on the crystal package. In production, this crystal code is read via a 2-dimensional bar code reader and the parameters are saved.

This oscillator is temperature compensated to an accuracy of +/-2.5 PPM from -30 to 60 degrees C. The temperature compensation scheme is implemented by an algorithm that uses five crystal

parameters (four characterize the inverse Bechmann voltage curve and one for frequency accuracy of the reference oscillator at 25 degrees C). This algorithm is implemented by the LVFRAC-N (U200) at the power up of the radio.

TCXO Y200, along with its corresponding circuitry R204, R205, R210, and C2053, are not placed as the temperature compensated crystal proved to be reliable.

4.2 Fractional-N Synthesizer

The LVFRAC-N U200 consists of a pre-scaler, programmable loop divider, control divider logic, phase detector, charge pump, A/D converter for low frequency digital modulation, balanced attenuator used to balance the high and low frequency analog modulation, 13V positive voltage multiplier, serial interface for control, and a super filter for the regulated 5 volts.

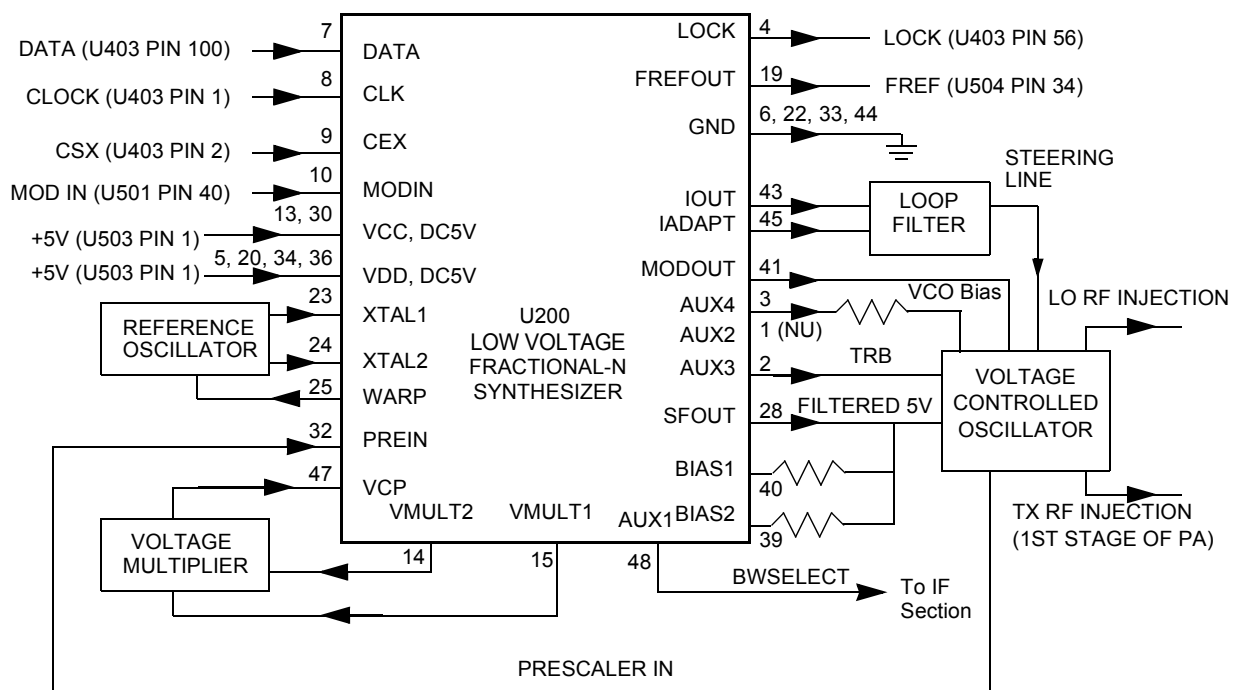

Figure 2-3 UHF Synthesizer Block Diagram

A voltage of 5V applied to the super filter input (U200, pin 30) supplies an output voltage of 4.5Vdc (VSF) at U200, pin 28. This supplies 4.5 V to the VCO Buffer IC U201.

To generate a high voltage to supply the phase detector (charge pump) output stage at pin VCP (U200, pin 47) while using a low voltage 3.3Vdc supply, a 13V positive voltage multiplier is used (D200, D201, and capacitors C2024, 2025, 2026, 2055, 2027, 2001).

Output lock (U200, pin 4) provides information about the lock status of the synthesizer loop. A high level at this output indicates a stable loop. A 16.8 MHz reference frequency is provided at U200, pin 19.

4.3 Voltage Controlled Oscillator (VCO)

The Voltage Controlled Oscillator (VCO) consists of the VCO/Buffer IC (VCOBIC, U201), the TX and RX tank circuits, the external RX buffer stages, and the modulation circuitry.

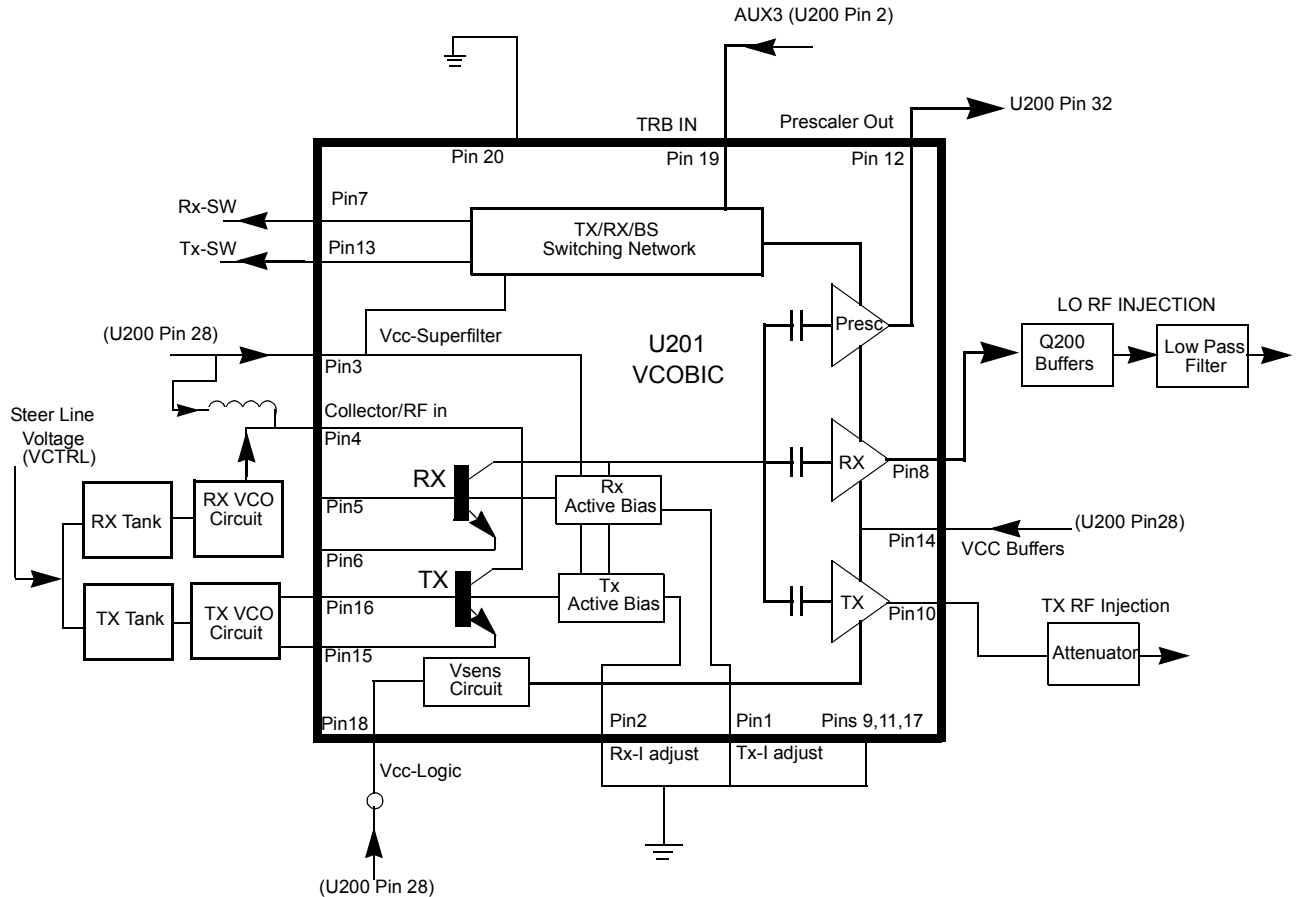

Figure 2-4 UHF VCO Block Diagram

The VCOBIC together with the LVFRAC-N (U200) generate the required frequencies in both transmit and receive modes. The TRB line (U201, pin 19) determines which VCO and buffer is enabled (high being TX output at pin 10, low being RX output at pin 8). A sample of the signal from the enabled output is routed from U201, pin 12 (PRESC_OUT), via a low pass filter to U200, pin 32 (PREIN).

A steering line voltage between 3.0V and 10.0V at varactor D204 tunes the TX VCO through the frequency range of 438-470MHz, and at D203 tunes the RX VCO through the frequency range of 393.15-425.15MHz.

The external RX amplifier is used to increase the output from U201, pin 8 from 3-4 dBm to the required 10dBm for proper mixer operation. In TX mode, the modulation signal from the LVFRAC-N (U200, pin 41) is applied to the VCO by way of the modulation circuit D205, R212, R211, C2073.

4.4 Synthesizer Operation

The synthesizer consists of a low voltage FRAC-N IC (LVFRAC-N), reference oscillator, charge pump circuits, loop filter circuit, and DC supply. The output signal (PRESC_OUT) of the VCOBIC (U201, pin 12) is fed to the PREIN, pin 32 of U200 via a low pass filter which attenuates harmonics and provides a correct input level to the LVFRAC-N in order to close the synthesizer loop.

The pre-scaler in the synthesizer (U200) is a dual modulus pre-scaler with selectable divider ratios. The divider ratio of the pre-scaler is controlled by the loop divider, which in turn receives its inputs via the SPI. The output of the pre-scaler is applied to the loop divider. The output of the loop divider is connected to the phase detector, which compares the loop divider's output signal with the reference signal. The reference signal is generated by dividing down the signal of the reference oscillator (Y201).

The output signal of the phase detector is a pulsed dc signal that is routed to the charge pump. The charge pump outputs a current from U200, pin 43 (IOUT). The loop filter (consisting of R224, R217, R234, C2074, C2078, C2028, and L205) transforms this current into a voltage that is applied the varactor diodes D203 and D204 for RX and TX respectively. The output frequency is determined by this control voltage. The current can be set to a value fixed in the LVFRAC-N or to a value determined by the currents flowing into BIAS 1 (U200, pin 40) or BIAS 2 (U200, pin 39). The currents are set by the value of R200 or R206 respectively. The selection of the three different bias sources is done by software programming.

To modulate the synthesizer loop, a two-spot modulation method is utilized via the MODIN (U200, pin 10) input of the LVFRAC-N. The audio signal is applied to both the A/D converter (low frequency path) and the balance attenuator (high frequency path). The A/D converter converts the low frequency analog modulating signal into a digital code which is applied to the loop divider, thereby causing the carrier to deviate. The balance attenuator is used to adjust the VCO's deviation sensitivity to high frequency modulating signals. The output of the balance attenuator is presented at the MODOUT port of the LVFRAC-N (U200, pin 41) and connected to the VCO modulation varactor D205.

5.0 Controller Theory of Operation

This section provides a detailed theory of operation for the radio and its components. The main radio is a single-board design, consisting of the transmitter, receiver, and controller circuits. A control head is connected by an extension cable. The control head contains LED indicators, a microphone connector, buttons, and speaker.

In addition to the power cable and antenna cable, an accessory cable can be attached to a connector on the rear of the radio. The accessory cable enables you to connect accessories to the radio, such as an external speaker, emergency switch, foot-operated PTT, and ignition sensing, etc.

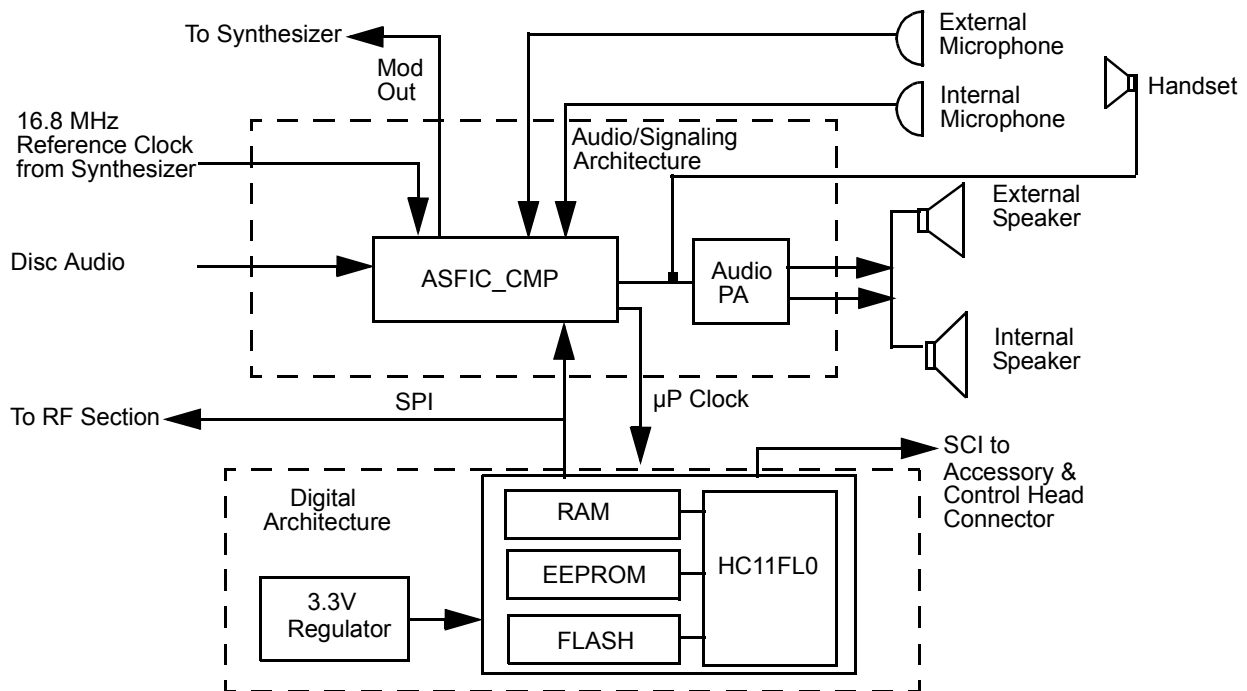

Figure 2-5 Controller Block Diagram

5.1 Radio Power Distribution

Voltage distribution is provided by five separate devices:

- U514 P-cH FET - Batt + (Ext_SWB+)
- U501 LM2941T - 9.3V
- U503 LP2951CM - 5V
- U508 MC 33269DTRK - 3.3V
- U510 LP2986ILDIX - 3.3V Digital

The DC voltage applied to connector P2 supplies power directly to the following circuitry:

- Electronic on/off control
- RF power amplifier
- 12 volts P-cH FET -U514
- 9.3 volt regulator
- Audio PA

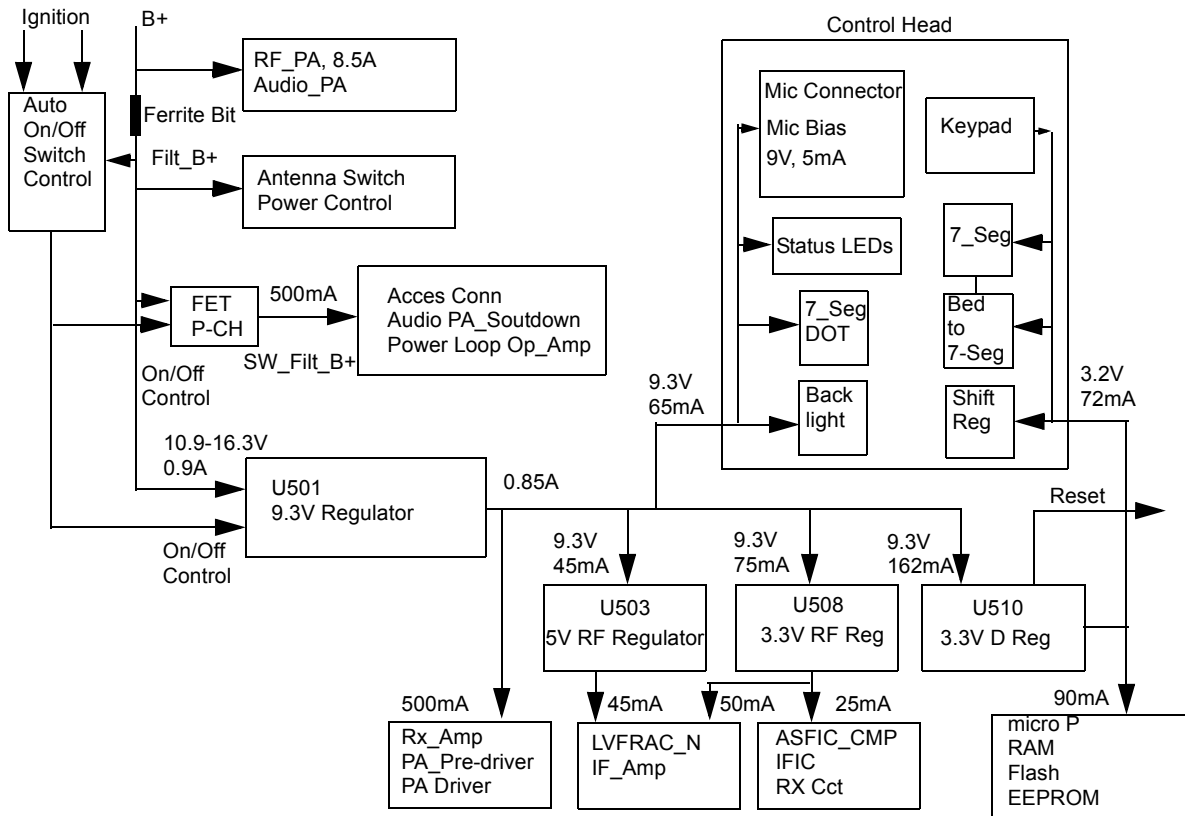

Figure 2-6 DC Power Distribution Block Diagram

Regulator U501 is used to generate the 9.3 volts required by some audio circuits, the RF circuitry and power control circuitry. Input and output capacitors are used to reduce high frequency noise. Resistors R5001 / R5081 set the output voltage of the regulator. This regulator output is electronically enabled by a 0 volt signal on pin 2. Q502, Q505 and R5038 are used to disable the regulator when the radio is turned off.

Voltage regulator U510 provides 3.3 volts for the digital circuitry. Operating voltage is from the regulated 9.3V supply. Input and output capacitors are used to reduce high frequency noise and provide proper operation during battery transients. U510 provides a reset output that goes to 0 volts if the regulator output goes below 3.1 volts. This is used to reset the controller to prevent improper operation.

Voltage regulator U508 provides 3.3V for the RF circuits and ASFIC_CMP. Input and output capacitors are used to reduce the high frequency noise and provide proper operation during battery transients.

Voltage regulator U503 provides 5V for the RF circuits. Input and output capacitors are used to reduce the high frequency noise and provide proper operation during battery transients.

VSTBY is used only for GM3689 5-tone radios.

The voltage VSTBY, which is derived directly from the supply voltage by components R5103 and VR502, is used to buffer the internal RAM. Capacitor C5120 allows the battery voltage to be disconnected for a couple of seconds without losing RAM parameters. Dual diode D501 prevents radio circuitry from discharging this capacitor. When the supply voltage is applied to the radio, C5120 is charged via R5103 and D501.

5.2 Protection Devices

Diode VR500 acts as protection against ESD, wrong polarity of the supply voltage, and load dump. VR692 - VR699 are for ESD protection.

5.3 Automatic On/Off

The radio can be switched ON in any one of the following three ways:

- On/Off switch. (No Ignition Mode)
- Ignition and On/Off switch (Ignition Mode)
- Emergency

5.3.1 No Ignition Mode

When the radio is connected to the car battery for the first time, Q500 will be in saturation, Q503 will cut-off, Filt_B+ will pass through R5073, D500, and S5010-pin 6 (On/Off switch). When S5010 is ON, Filt_B+ will pass through S5010-pin5, D511, R5069, R5037 and base of Q505 and move Q505 into saturation. This pulls U501-pin2 through R5038, D502 to 0.2V and turns On U514 and U501 9.3V regulator which supplies voltage to all other regulators and consequently turns the radio on, When U504 (ASFIC_CMP) gets 3.3V, GCB2 goes to 3.3V and holds Q505 in saturation, for soft turn off.

5.3.2 Ignition Mode

When ignition is connected for the first time, it will force high current through Q500 collector, This will move Q500 out of saturation and consequently Q503 will cut-off. S5010 pin 6 will get ignition voltage through R601 (for load dump), R610, (R610 & C678 are for ESD protection), VR501, R5074, and D500. When S5010 is ON, Filt_B+ passes through S5010-pin 5, D511, R5069, R5037 and base of Q505 and inserts Q505 into saturation. This pulls U501-pin 2 through R5038, D502 to 0.2V and turns on U514 and U501 9.3V regulator which supply voltage to all other regulators and turns the radio on, When U504 (ASFIC_CMP) get 3.3V supply, GCB2 goes to 3.3V and holds Q505 in saturation state to allow soft turn off,

When ignition is off Q500, Q503 will stay at the same state so S5010 pin 6 will get 0V from Ignition, Q504 goes from Sat to Cut, ONOFF_SENSE goes to 3.3V and it indicates to the radio to soft turn itself by changing GCB2 to '0' after de registration if necessary.

5.3.3 Emergency Mode

The emergency switch (P1 pin 9), when engaged, grounds the base of Q506 via EMERGENCY_ACCES_CONN. This switches Q506 to off and consequently resistor R5020 pulls the collector of Q506 and the base of Q506 to levels above 2 volts. Transistor Q502 switches on and pulls U501 pin2 to ground level, thus turning ON the radio. When the emergency switch is released R5030 pulls the base of Q506 up to 0.6 volts. This causes the collector of transistor Q506 to go low (0.2V), thereby switching Q502 to off.

While the radio is switched on, the μ P monitors the voltage at the emergency input on the accessory connector via U403-pin 62. Three different conditions are distinguished: no emergency kit is connected, emergency kit connected (unpressed), and emergency press.

If no emergency switch is connected or the connection to the emergency switch is broken, the resistive divider R5030 / R5049 will set the voltage to about 3.14 volts (indicates no emergency kit found via EMERGENCY_SENSE line). If an emergency switch is connected, a resistor to ground within the emergency switch will reduce the voltage on EMERGENCY_SENSE line, and indicate to the μ P that the emergency switch is operational. An engaged emergency switch pulls line EMERGENCY_SENSE line to ground level. Diode VR503 limits the voltage to protect the μ P input.

While EMERGENCY_ACCES_CONN is low, the μ P starts execution, reads that the emergency input is active through the voltage level of μ P pin 64, and sets the DC POWER ON output of the ASFIC CMP pin 13 to a logic high. This high will keep Q505 in saturation for soft turn off.

5.4 Microprocessor Clock Synthesiser

The clock source for the μ P system is generated by the ASFIC CMP (U504). Upon power-up the synthesizer IC (FRAC-N) generates a 16.8 MHz waveform that is routed from the RF section to the ASFIC CMP pin 34. For the main board controller the ASFIC CMP uses 16.8 MHz as a reference input clock signal for its internal synthesizer. The ASFIC CMP, in addition to audio circuitry, has a programmable synthesizer which can generate a synthesized signal ranging from 1200Hz to 32.769MHz in 1200Hz steps.

When power is first applied, the ASFIC CMP will generate its default 3.6864MHz CMOS square wave UP_CLK (on U504 pin 28) and this is routed to the μ P (U403 pin 90). After the μ P starts operation, it reprograms the ASFIC CMP clock synthesizer to a higher UP_CLK frequency (usually 7.3728 or 14.7456 MHz) and continues operation.

The ASFIC CMP may be reprogrammed to change the clock synthesizer frequencies at various times depending on the software features that are executing. In addition, the clock frequency of the synthesizer is changed in small amounts if there is a possibility of harmonics of the clock source interfering with the desired radio receive frequency.

The ASFIC CMP synthesizer loop uses C5025, C5024 and R5033 to set the switching time and jitter of the clock output. If the synthesizer cannot generate the required clock frequency it will switch back to its default 3.6864MHz output.

Because the ASFIC CMP synthesizer and the μ P system will not operate without the 16.8 MHz reference clock it (and the voltage regulators) should be checked first when debugging the system.

5.5 Serial Peripheral Interface (SPI)

The μ P communicates to many of the IC's through its SPI port. This port consists of SPI TRANSMIT DATA (MOSI) (U403-pin100), SPI RECEIVE DATA (MISO) (U403-pin 99), SPI CLK (U0403-pin1) and chip select lines going to the various IC's, connected on the SPI PORT (BUS). This BUS is a synchronous bus, in that the timing clock signal CLK is sent while SPI data (SPI TRANSMIT DATA or SPI RECEIVE DATA) is sent. Therefore, whenever there is activity on either SPI TRANSMIT DATA or SPI RECEIVE DATA there should be a uniform signal on CLK. The SPI TRANSMIT DATA is used to send serial from a μ P to a device, and SPI RECEIVE DATA is used to send data from a device to a μ P.

There are two IC's on the SPI BUS, ASFIC CMP (U504 pin 22)), and EEPROM (U400). In the RF sections there is one IC on the SPI BUS, the FRAC-N Synthesizer. The chip select line CSX from U403 pin 2 is shared by the ASFIC CMP and FRAC-N Synthesizer. Each of these IC's check the SPI data and when the sent address information matches the IC's address, the following data is processed.

When the μ P needs to program any of these Is it brings the chip select line CSX to a logic "0" and then sends the proper data and clock signals. The amount of data sent to the various IC's are different; e.g., the ASFIC CMP can receive up to 19 bytes (152 bits). After the data has been sent the chip select line is returned to logic "1".

5.6 SBEP Serial Interface

The SBEP serial interface allows the radio to communicate with the Customer Programming Software (CPS), or the Universal Tuner via the Radio Interface Box (RIB) or the cable with internal RIB. This interface connects to the SCI pin via control head connector (J2-pin 17) and to the accessory connector P1-6 and comprises BUS+. The line is bi-directional, meaning that either the radio or the RIB can drive the line. The μ P sends serial data and it reads serial data via pin 97. Whenever the μ P detects activity on the BUS+ line, it starts communication.

5.7 General Purpose Input/Output

The controller provides six general purpose lines (PROG I/O) available on the accessory connector P1 to interface to external options. Lines PROG IN 3 and 6 are inputs, PROG OUT 4 is an output and PROG IN OUT 8, 12 and 14 are bi-directional. The software and the hardware configuration of the radio model define the function of each port.

- PROG IN 3 can be used as external PTT input, or others, set by the CPS. The μ P reads this port via pin 72 and Q412.
- PROG OUT 4 can be used as external alarm output, set by the CPS. Transistor Q401 is controlled by the μ P (U403 pin 55)
- PROG IN 6 can be used as normal input, set by the CPS. The μ P reads this port via pin 73 and Q411. This pin is also used to communicate with the RIB if resistor R421 is placed.
- DIG IN OUT 8,12,14 are bi-directional and use the same circuit configuration. Each port uses an output Q416, Q404, Q405 controlled by μ P pins 52, 53, 54. The input ports are read through μ P pins 74, 76, 77; using Q409, Q410, Q411

5.8 Normal Microprocessor Operation

For this radio, the μP is configured to operate in one of two modes, expanded and bootstrap. In expanded mode the μP uses external memory devices to operate, whereas in bootstrap operation the μP uses only its internal memory. In normal operation of the radio the μP is operating in expanded mode as described below.

During normal operation, the μP (U403) is operating in expanded mode and has access to 3 external memory devices; U400 (EEPROM), U402 (SRAM), U404 (Flash). Also, within the μP there are 3 Kilobytes of internal RAM, as well as logic to select external memory devices.

The external EEPROM (U400) space contains the information in the radio which is customer specific, referred to as the codeplug. This information consists of items such as: 1) what band the radio operates in, 2) what frequencies are assigned to what channel, and 3) tuning information.

The external SRAM (U402) as well as the μP 's own internal RAM space are used for temporary calculations required by the software during execution. All of the data stored in both of these locations is lost when the radio powers off.

The μP provides an address bus of 16 address lines (ADDR 0 - ADDR 15), and a data bus of 8 data lines (DATA 0 - DATA 7). There are also 3 control lines; CSPROG (U403-38) to chip select U404-pin 30 (FLASH), CSGP2 (U403-pin 41) to chip select U404-pin 20 (SRAM) and PG7_R_W (U403-pin 4) to select whether to read or to write. The external EEPROM (U400-pin1).

When the μP is functioning normally, the address and data lines should be toggling at CMOS logic levels. Specifically, the logic high levels should be between 3.1 and 3.3V, and the logic low levels should be between 0 and 0.2V. No other intermediate levels should be observed, and the rise and fall times should be $<30\text{ns}$.

The low-order address lines (ADDR 0 - ADDR 7) and the data lines (DATA 0-DATA 7) should be toggling at a high rate, e.g., you should set your oscilloscope sweep to $1\mu\text{s}/\text{div}$. or faster to observe individual pulses. High speed CMOS transitions should also be observed on the μP control lines.

On the μP the lines XIRQ (U403-pin 48), MODA LIR (U403-pin 58), MODB VSTPY (U403-pin 57) and RESET (U403-pin 94) should be high at all times during normal operation. Whenever a data or address line becomes open or shorted to an adjacent line, a common symptom is that the RESET line goes low periodically, with the period being in the order of 20ms. In the case of shorted lines you may also detect the line periodically at an intermediate level, i.e. around 2.5V when two shorted lines attempt to drive to opposite rails.

The MODA LIR (U403-pin 58) and MODB VSTPY (U403-pin 57) inputs to the μP must be at a logic "1" for it to start executing correctly. After the μP starts execution it will periodically pulse these lines to determine the desired operating mode. While the Central Processing Unit (CPU) is running, MODA LIR is an open-drain CMOS output which goes low whenever the μP begins a new instruction. An instruction typically requires 2-4 external bus cycles, or memory fetches.

There are eight analog-to-digital converter ports (A/D) on U403 labelled within the device block as PEO-PE7. These lines sense the voltage level ranging from 0 to 3.3V of the input line and convert that level to a number ranging from 0 to 255 which is read by the software to take appropriate action.

5.9 Static Random Access Memory (SRAM)

The SRAM (U402) contains temporary radio calculations or parameters that can change very frequently, and which are generated and stored by the software during its normal operation. The information is lost when the radio is turned off.

The device allows an unlimited number of write cycles. SRAM accesses are indicated by the CS signal U402 (which comes from U403-CSGP2) going low. U402 is commonly referred to as the external RAM as opposed to the internal RAM which is the 3 Kilobytes of RAM which is part of the 68HC11FLO. Both RAM spaces serve the purpose. However, the internal RAM is used for the calculated values which are accessed most often.

Capacitor C402 and C411 serves to filter out any AC noise which may ride on +3.3 V at U402

6.0 Control Board Audio and Signalling Circuits

6.1 Audio Signalling Filter IC and Compander (ASFIC CMP)

The ASFIC CMP (U504) used in the controller has the following four functions:

1. RX/TX audio shaping, i.e. filtering, amplification, attenuation
2. RX/TX signaling, PL/DPL/HST/MDC
3. Squelch detection
4. μ P clock signal generation

The ASFIC CMP is programmable through the SPI BUS (U504 pins-20/21/22), normally receiving 19 bytes. This programming sets up various paths within the ASFIC CMP to route audio and/or signaling signals through the appropriate filtering, gain and attenuator blocks. The ASFIC CMP also has 6 General Control Bits GCB0-5 which are CMOS level outputs and used for the following:

- GCB0 - BW Select
- GCB1 - switches the audio PA On/Off
- GCB2 - DC Power On switches the voltage regulator (and the radio) on and off
- GCB3 - Control on MUX U509 pin 9 to select between Low Cost Mic path to STD Mic Path
- GCB4 - Control on MUX U509 pin 11 to select between Flat RX path to filtered RX path on the accessory connector.
- GCB5 - Control on MUX U509 pin 10 to select between Flat TX path mute and Flat TX path

7.0 Transmit Audio Circuits

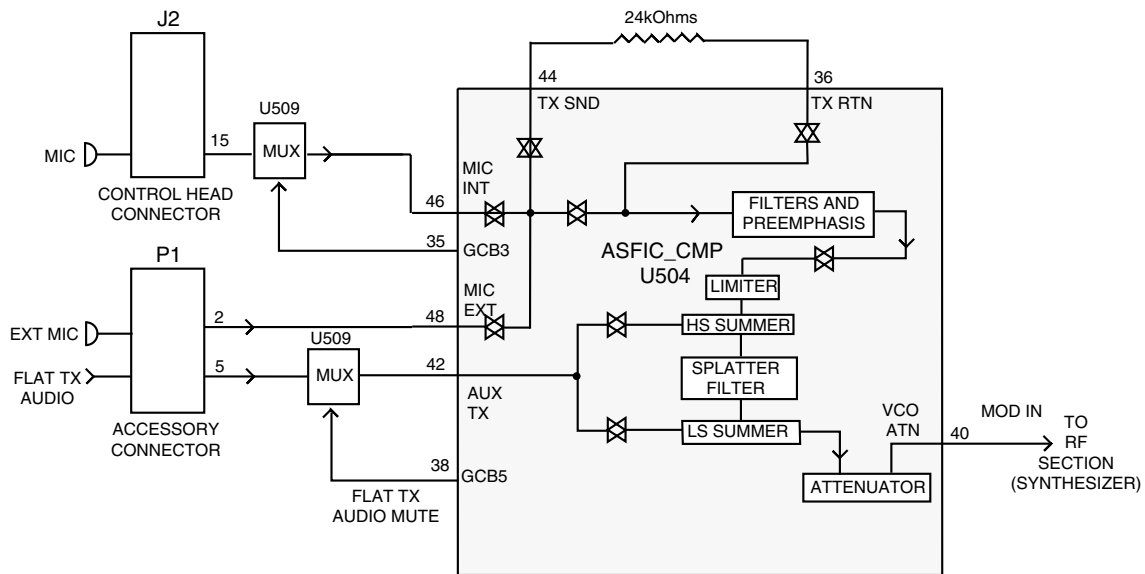

Figure 2-7 Transmit Audio Paths

7.1 Microphone Input Path

The radio supports 2 distinct microphone paths known as internal (from control head J2-15) and external mic (from accessory connector P1-2) and an auxiliary path (FLAT TX AUDIO, from accessory connector P1-5). The microphones used for the radio require a DC biasing voltage provided by a resistive network.

The two microphone audio input paths enter the ASFIC CMP at U504-pin 48 (external mic) and U504-pin 46 (internal mic). The microphone is plugged into the radio control head and connected to the audio DC via J2-pin 15. The signal is then routed via C5045 to MUX U509 that select between two paths with different gain to support Low Cost Mic (Mic with out amplifier in it) and Standard Mic.

7.1.1 Low Cost Microphone

Hook Pin is shorted to Pin 1(9.3V) inside the Low Cost Mic, This routes 9.3V to R429, and creates 2.6V on MIC_SENSE (u.P U403-67) by Voltage Divider R429/R430. U403 senses this voltage and sends command to ASFIC_CMP U504 to get GCB3 = '0'. The audio signal is routed from C5045 via U509-5 (Z0), R5072, U507, R5026, C5091, R5014 via C5046 to U504- 46 int. mic (C5046 100nF creates a159Hz pole with U504- 46 int mic impedance of 16Kohm).

7.1.2 Standard Microphone

Hook Pin is shorted to the hook mic inside the standard Mic, If the mic is out off hook, 3.3V is routed to R429 via R458, D401, and it create 0.7V on MIC_SENSE (u.P U403-67) by Voltage Divider R429/R430. U403 senses this voltage and sends command to ASFIC_CMP U504 to get GCB3 = '1'. The audio signal is routed from C5045 via U509-3 (Z1), R5072, U507, R5026, C5091, R5014 via C5046 to U504- 46 int mic (C5046 100nF create a159Hz pole with U504- 46 int mic impedance of 16Kohm). 9.3VDC is routed via R5077, R5075 to J2-15, It create 4.65V with Mic Impedance. C5010 supplies AC Ground to create AC impedance of 510 Ohms via R5075. and Filter 9.3V DC mic bias supply.

Note: The audio signal at U504-pin 46 should be approximately 12mV for 1.5kHz or 3kHz of deviation with 12.5kHz or 25kHz channel spacing.

The external microphone signal enters the radio on accessory connector P1 pin 2 and is routed via line EXT MIC to R5054. R5078 and R5076 provide the 9.3Vdc bias. Resistive divider R5054/ R5070 divide the input signal by 5.5 and provide input protection for the CMOS amplifier input. R5076 and C5009 provide a 510 ohm AC path to ground that sets the input impedance for the microphone and determines the gain based on the emitter resistor in the microphone's amplifier circuit.

C5047 serves as a DC blocking capacitor. The audio signal at U504-pin 48 should be approximately 14mV for 1.5kHz or 3kHz of deviation with 12.5kHz or 25kHz channel spacing.

The FLAT TX AUDIO signal from accessory connector P1-pin 5 is fed to the ASFIC CMP (U504 pin 42 through U509 pin 2 to U509 pin 15 via U506 OP-AMP circuit and C5057.

The ASFIC has an internal AGC that can control the gain in the mic audio path. The AGC can be disabled / enabled by the μ P. Another feature that can be enabled or disabled in the ASFIC is the VOX. This circuit, along with Capacitor C5023 at U504-pin 7, provides a DC voltage that can allow the μ P to detect microphone audio. The ASFIC can also be programmed to route the microphone audio to the speaker for public address operation.

7.2 PTT Sensing and TX Audio Processing

Internal microphone PTT is sensed by μ P U403 pin 71. Radio transmits when this pin is "0" and selects inside the ASFIC_CMP U504 internal Mic path. When the internal Mic PTT is "0" then external Mic PTT is grounded via D402. External Mic PTT is sensed by U403 pin 72 via Q412 circuits. The radio transmits when this pin is "0" and selects inside the ASFIC_CMP U504 External Mic path.

Inside the ASFIC CMP, the mic audio is filtered to eliminate frequency components outside the 300-3000Hz voice band, and pre-emphasized if pre-emphasis is enabled. The signal is then limited to prevent the transmitter from over deviating. The limited mic audio is then routed through a summer, which is used to add in signaling data, and then to a splatter filter to eliminate high frequency spectral components that could be generated by the limiter. The audio is then routed to an attenuator, which is tuned in the factory or the field to set the proper amount of FM deviation. The TX audio emerges from the ASFIC CMP at U504-pin 40 MOD IN, at which point it is routed to the RF section.

8.0 Transmit Signalling Circuits

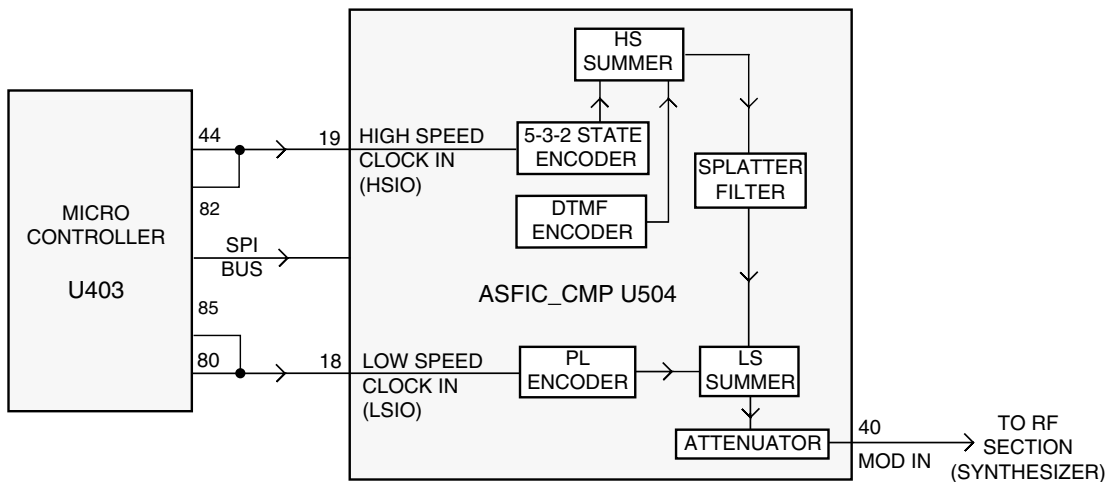

Figure 2-8 Transmit Signalling Path

From a hardware point of view, there are 3 types of signaling:

- Sub-audible data (PL / DPL / Connect Tone) that gets summed with transmit voice or signaling,
- DTMF data for telephone communication in trunked and conventional systems, and
- Audible signaling including MDC and high-speed trunking.

Note: All three types are supported by the hardware while the radio software determines which signaling type is available.

8.1 Sub-Audio Data (PL/DPL)

Sub-audible data implies signaling whose bandwidth is below 300Hz. PL and DPL waveforms are used for conventional operation and connect tones for trunked voice channel operation. The trunking connect tone is simply a PL tone at a higher deviation level than PL in a conventional system. Although it is referred to as “sub-audible data”, the actual frequency spectrum of these waveforms may be as high as 250 Hz, which is audible to the human ear. However, the radio receiver filters out any audio below 300Hz, so these tones are never heard in the actual system.

Only one type of sub-audible data can be generated by U504 (ASFIC CMP) at any one time. The process is as follows, using the SPI BUS, the μ P programs the ASFIC CMP to set up the proper low-speed data deviation and select the PL or DPL filters. The μ P then generates a square wave which strobes the ASFIC PL / DPL encode input LSIO U504-pin 18 at twelve times the desired data rate. For example, for a PL frequency of 103Hz, the frequency of the square wave would be 1236Hz.

This drives a tone generator inside U504 which generates a staircase approximation to a PL sine wave or DPL data pattern. This internal waveform is then low-pass filtered and summed with voice or data. The resulting summed waveform then appears on U504-pin 40 (MOD IN), where it is sent to the RF board as previously described for transmit audio. A trunking connect tone would be generated in the same manner as a PL tone.

8.2 High Speed Data

High speed data refers to the 3600 baud data waveforms, known as Inbound Signaling Words (ISWs) used in a trunking system for high speed communication between the central controller and the radio. To generate an ISW, the μ P first programs the ASFIC CMP (U504) to the proper filter and gain settings. It then begins strobing U504-pin 19 (HSIO) with a pulse when the data is supposed to change states. U504's 5-3-2 State Encoder (which is in a 2-state mode) is then fed to the post-limiter summer block and then the splatter filter. From that point it is routed through the modulation attenuator and then out of the ASFIC CMP to the RF board. MDC is generated in much the same way as trunking ISW. However, in some cases these signals may also pass through a data pre-emphasis block in the ASFIC CMP. Also these signaling schemes are based on sending a combination of 1200 Hz and 1800 Hz tones only. Microphone audio is muted during high speed data signaling.

8.3 Dual Tone Multiple Frequency (DTMF) Data

DTMF data is a dual tone waveform used during phone interconnect operation. It is the same type of tones which are heard when using a "Touch Tone" telephone.

There are seven frequencies, with four in the low group (697, 770, 852, 941Hz) and three in the high group (1209, 1336, 1477Hz). The high-group tone is generated by the μ P (U403-46) strobing U504-19 at six times the tone frequency for tones less than 1440Hz or twice the frequency for tones greater than 1440Hz. The low group tone is generated by the ASFIC CMP, controlled by the μ P via SPI bus. Inside U504 the low-group and high-group tones are summed (with the amplitude of the high group tone being approximately 2 dB greater than that of the low group tone) and then pre-emphasized before being routed to the summer and splatter filter. The DTMF waveform then follows the same path as was described for high-speed data.

9.0 Receive Audio Circuits

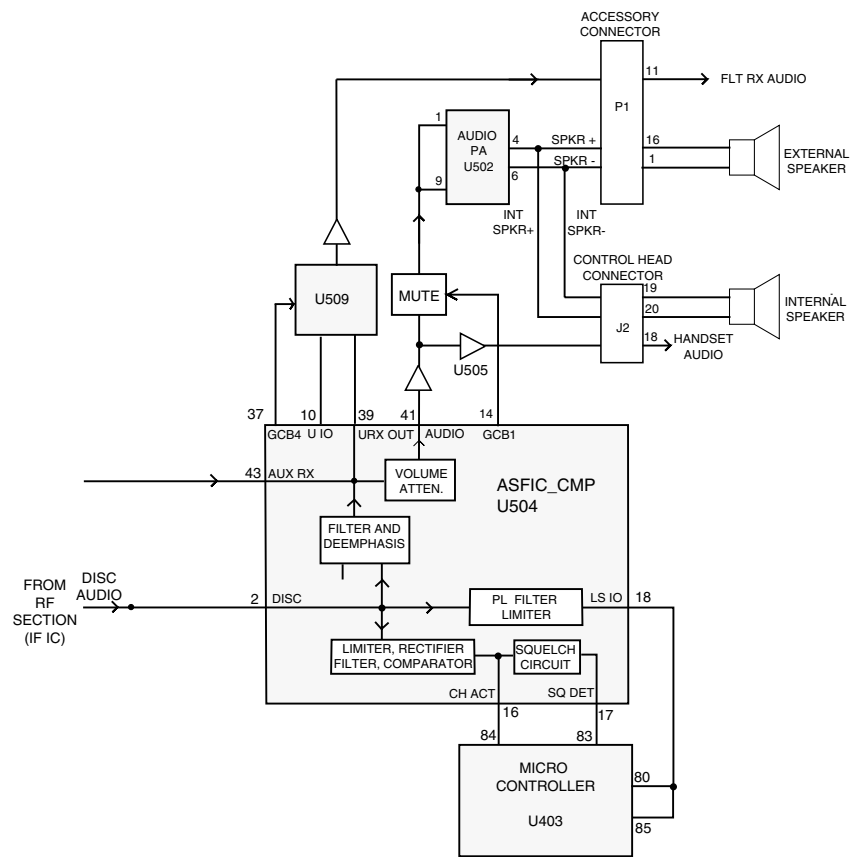

Figure 2-9 Receive Audio Paths

9.1 Squelch Detect

The radio's RF circuits are constantly producing an output at the discriminator (IF IC). This signal (DISC AUDIO) is routed to the ASFIC CMP's squelch detect circuitry input DISC (U504-pin 2). All of the squelch detect circuitry is contained within the ASFIC CMP. Therefore from a user's point of view, DISC AUDIO enters the ASFIC CMP, and the ASFIC CMP produces two CMOS logic outputs based on the result. They are CH ACT (U504-16) and SQ DET (U504-17).

The squelch signal entering the ASFIC CMP is amplified, filtered, attenuated, and rectified. It is then sent to a comparator to produce an active high signal on CH ACT. A squelch tail circuit is used to produce SQ DET (U504-17) from CH ACT. The state of CH ACT and SQ DET is high (logic "1") when carrier is detected, otherwise low (logic "0").

CH ACT is routed to the μ P pin 84 while SQ DET is routed to the μ P pin 83.

SQ DET is used to determine all audio mute / unmute decisions except for Conventional Scan. In this case CH ACT is a pre-indicator as it occurs slightly faster than SQ DET.

9.2 Audio Processing and Digital Volume Control

The receiver audio signal (DISC AUDIO) enters the controller section from the IF IC where it is DC coupled to ASFIC CMP via the DISC input U504-pin 2. The signal is then applied to both the audio and the PL/DPL paths

The audio path has a programmable amplifier, whose setting is based on the channel bandwidth being received, an LPF filter to remove any frequency components above 3000Hz, and a HPF to strip off any sub-audible data below 300Hz. Next, the recovered audio passes through a de-emphasis filter (if it is enabled to compensate for Pre-emphasis which is used to reduce the effects of FM noise). The IC then passes the audio through the 8-bit programmable attenuator whose level is set depending on the value of the volume control. Finally the filtered audio signal passes through an output buffer within the ASFIC CMP. The audio signal exits the ASFIC CMP at AUDIO output (U504 pin 41).

The μ P programs the attenuator, using the SPI BUS, based on the volume setting. The minimum / maximum settings of the attenuator are set by codeplug parameters.

Since sub-audible signaling is summed with voice information on transmit, it must be separated from the voice information before processing. Any sub-audible signaling enters the ASFIC CMP from the IF IC at DISC U504-2. Once inside, it goes through the PL/DPL path. The signal first passes through one of the two low-pass filters, either the PL low-pass filter or the DPL/LST low-pass filter. Either signal is then filtered and goes through a limiter and exits the ASFIC CMP at LSIO (U504-pin 18). At this point, the signal will appear as a square wave version of the sub-audible signal which the radio received. The μ P U403 pin 80 will decode the signal directly to determine if it is the tone / code which is currently active on that mode.

9.3 Audio Amplification Speaker (+) Speaker (-)

The output of the ASFIC CMP's digital volume pot, U504-pin 41 is routed through DC blocking capacitor C5049 to the audio PA (U502 pin 1 and 9).

The audio power amplifier has one inverted and one non-inverted output that produces the differential audio output SPK+/SPK- (U502 pins 4 and 6)

The audio PA is enabled via the ASFIC CMP (U504-GCB1). When the base of Q501 is low, the transistor is off and U502-pin 8 is high, using pull up resistor R5041, and the audio PA is ON. The voltage at U502-pin 8 must be above 8.5Vdc to properly enable the device.

If the voltage is between 3.3 and 6.4V, the device will be active but has its input (U502-pins 1/9) off. This is a mute condition which is used to prevent an audio pop when the PA is enabled.

The SPK+ and SPK- outputs of the audio PA have a DC bias which varies proportionately with B+ (U502- pin 7). B+ of 11V yields a DC offset of 5V, and B+ of 17V yields a DC offset of 8.5V. If either of these lines is shorted to ground, it is possible that the audio PA will be damaged. SPK+ and SPK- are routed to the accessory connector (P1-pin 1 and 16) and to the control head (connector J2-pins 19 and 20).

9.4 Handset Audio

Certain handheld accessories have a speaker within them which require a different voltage level than that provided by U502. For these devices HANDSET AUDIO is available at control head connector J2 pin18.

The received audio from the output of the ASFIC CMP's digital volume attenuator is routed to U505 pin 2 where it is amplified. This signal is routed from the output of the op-amp U505 to J2-pin 18. From the control head, the signal is sent directly to the microphone jack.

9.5 Filtered Audio and Flat Audio

The ASFIC CMP output audio at U504-pin 39 is filtered and de-emphasized, but has not gone through the digital volume attenuator. From ASFIC CMP U504-pin 39 the signal is routed via R5034 through gate U509-pin 12 and AC coupled to U505-pin 6. The gate controlled by ASFIC CMP port GCB4 selects between the filtered audio signal from the ASFIC CMP pin 39 (URXOUT) or the unfiltered (flat) audio signal from the ASFIC CMP pin 10 (UIO). Resistors R5034 and R5021 determine the gain of op-amp UU505-pin 6 for the filtered audio while R5032 and R5021 determine the gain for the flat Audio. The output of U505-pin 7 is then routed to P1 pin 11 via DC blocking capacitor C5003. Note that any volume adjustment of the signal on this path must be done by the accessory.

10.0 Receive Signalling Circuits

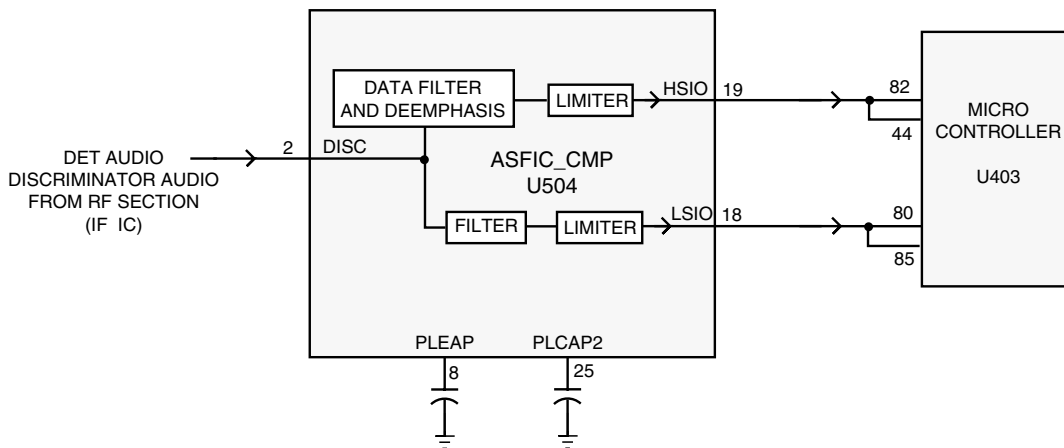

Figure 2-10 Receive Signalling Paths

10.1 Sub-Audio Data (PL/DPL) and High Speed Data Decoder

The ASFIC CMP (U504) is used to filter and limit all received data. The data enters the ASFIC CMP at input DISC (U504 pin 2). Inside U504 the data is filtered according to data type (HS or LS), then it is limited to a 0-3.3V digital level. The MDC and trunking high speed data appear at U504-pin 19, where it connects to the µP U403 pin 80.

The low speed limited data output (PL, DPL, and trunking LS) appears at U504-pin18, where it connects to the μ P U403-pin 80.

The low speed data is read by the μ P at twice the frequency of the sampling waveform; a latch configuration in the ASFIC CMP stores one bit every clock cycle. The external capacitors C5028, and C5026 set the low frequency pole for a zero crossings detector in the limiters for PL and HS data. The hysteresis of these limiters is programmed based on the type of received data.

10.2 Alert Tone Circuits

When the software determines that it needs to give the operator an audible feedback (for a good key press, or for a bad key press), or radio status (trunked system busy, phone call, circuit failures), it sends an alert tone to the speaker. It does so by sending SPI BUS data to U504 which sets up the audio path to the speaker for alert tones. The alert tone itself can be generated in one of two ways: internally by the ASFIC CMP, or externally using the μ P and the ASFIC CMP.

The allowable internal alert tones are 304, 608, 911, and 1823Hz. In this case a code contained within the SPI BUS load to the ASFIC CMP sets up the path and determines the tone frequency, and at what volume level to generate the tone. (It does not have to be related to the voice volume setting.)

For external alert tones, the μ P can generate any tone within the 100-3000Hz audio band. This is accomplished by the μ P generating a square wave which enters the ASFIC CMP at U504 pin 19. Inside the ASFIC CMP this signal is routed to the alert tone generator.

The output of the generator is summed into the audio chain just after the RX audio de-emphasis block. Inside U504, the tone is amplified and filtered, then passed through the 8-bit digital volume attenuator, which is typically loaded with a special value for alert tone audio. The tone exits at U504-pin 41 and is routed to the audio PA like receive audio.

Chapter 3

TROUBLESHOOTING CHARTS

This section contains detailed troubleshooting flowcharts. These charts should be used as a guide in determining the problem areas. They are not a substitute for knowledge of circuit operation and astute troubleshooting techniques. It is advisable to refer to the related detailed circuit descriptions in the theory of operation sections prior to troubleshooting a radio.

Most troubleshooting charts end up by pointing to an IC to replace. It is not always noted, but it is good practice to verify supplies and grounds to the affected IC and to trace continuity to the malfunctioning signal and related circuitry before replacing any IC. For instance, if a clock signal is not available at a destination, continuity from the source IC should be checked before replacing the source IC.

1.0 Troubleshooting Flow Chart for Receiver RF (Sheet 1 of 2)

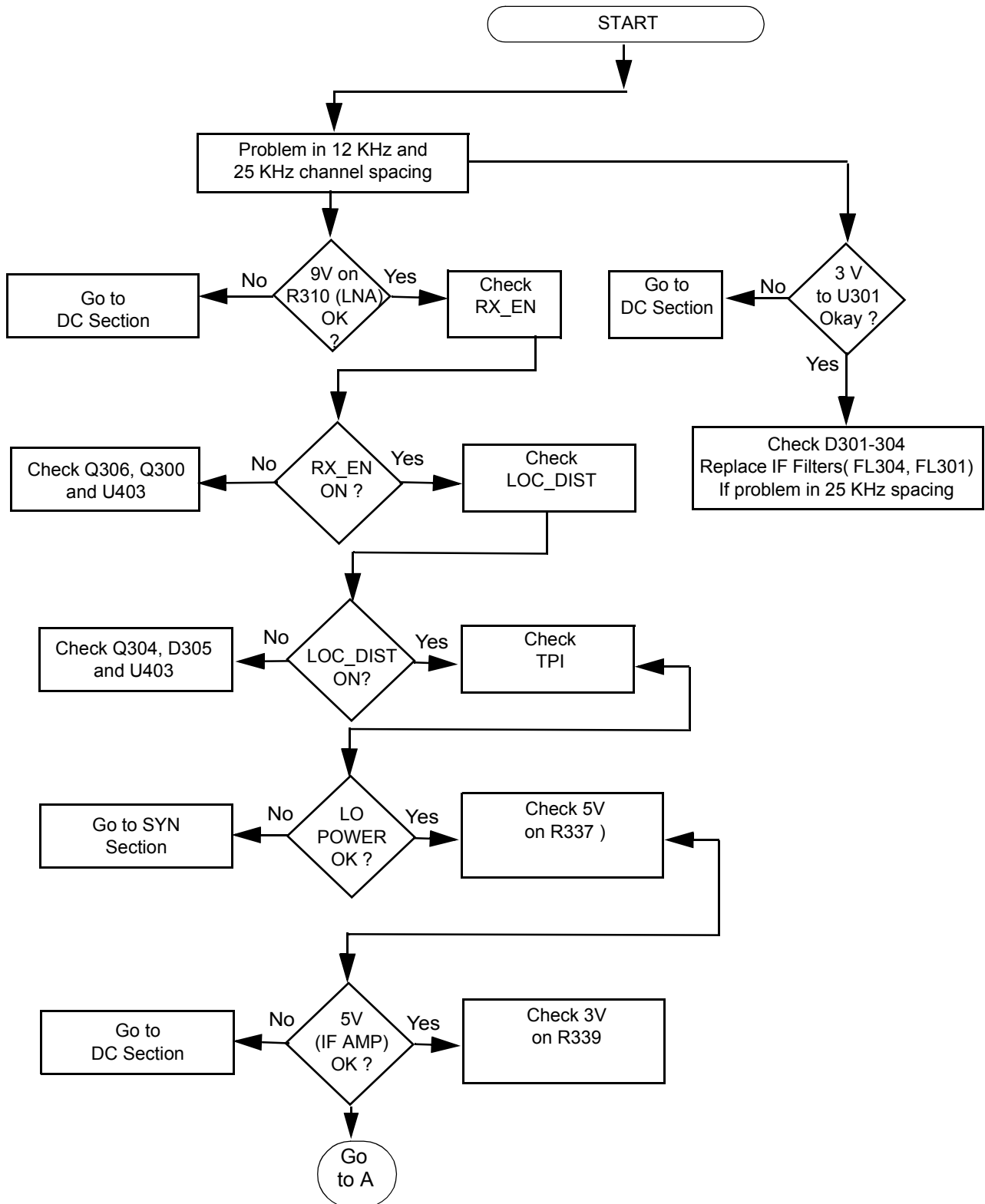

1.1 Troubleshooting Flow Chart for Receiver (Sheet 2 of 2)

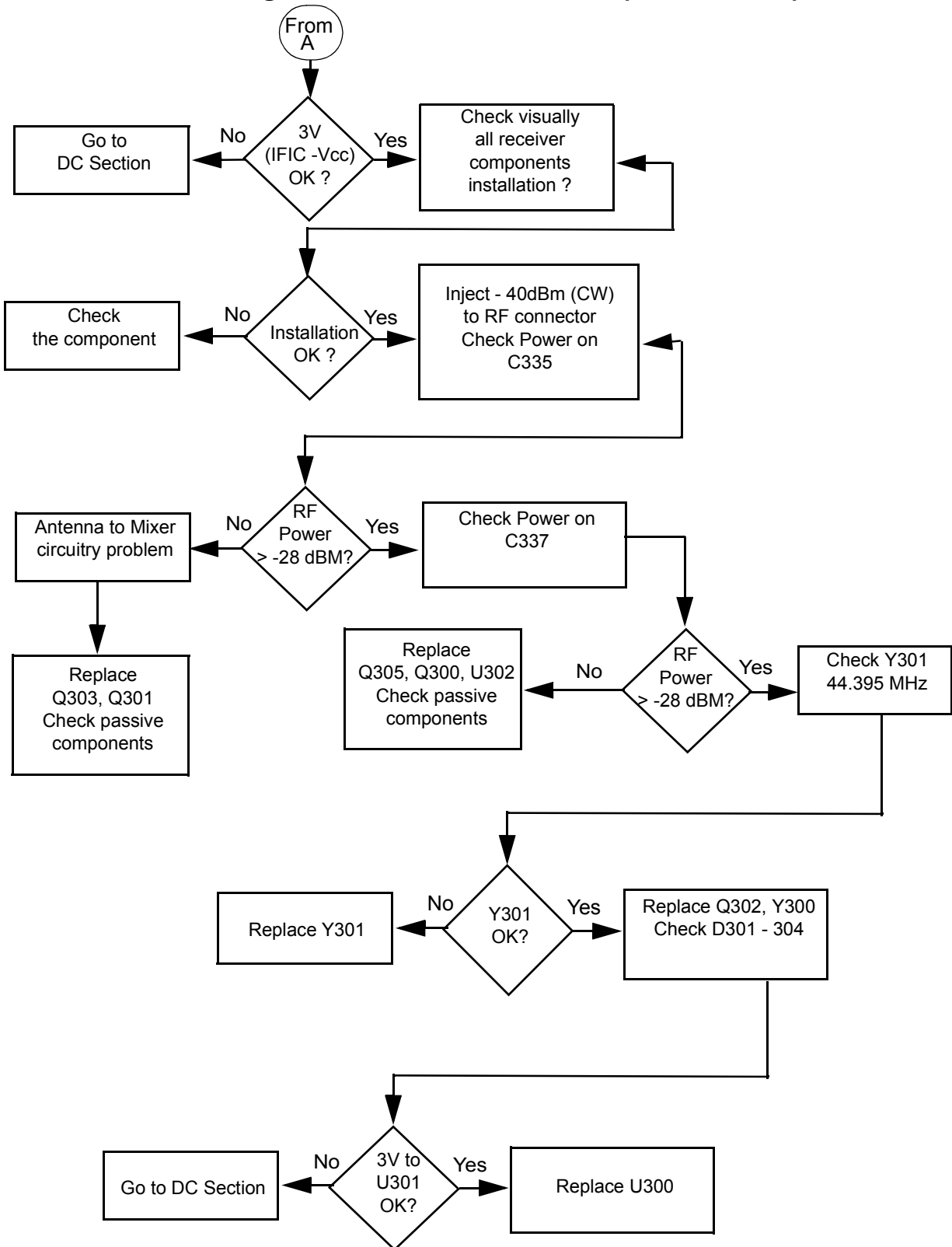

2.0 Troubleshooting Flow Chart for 40W Transmitter (Sheet 1 of 3)

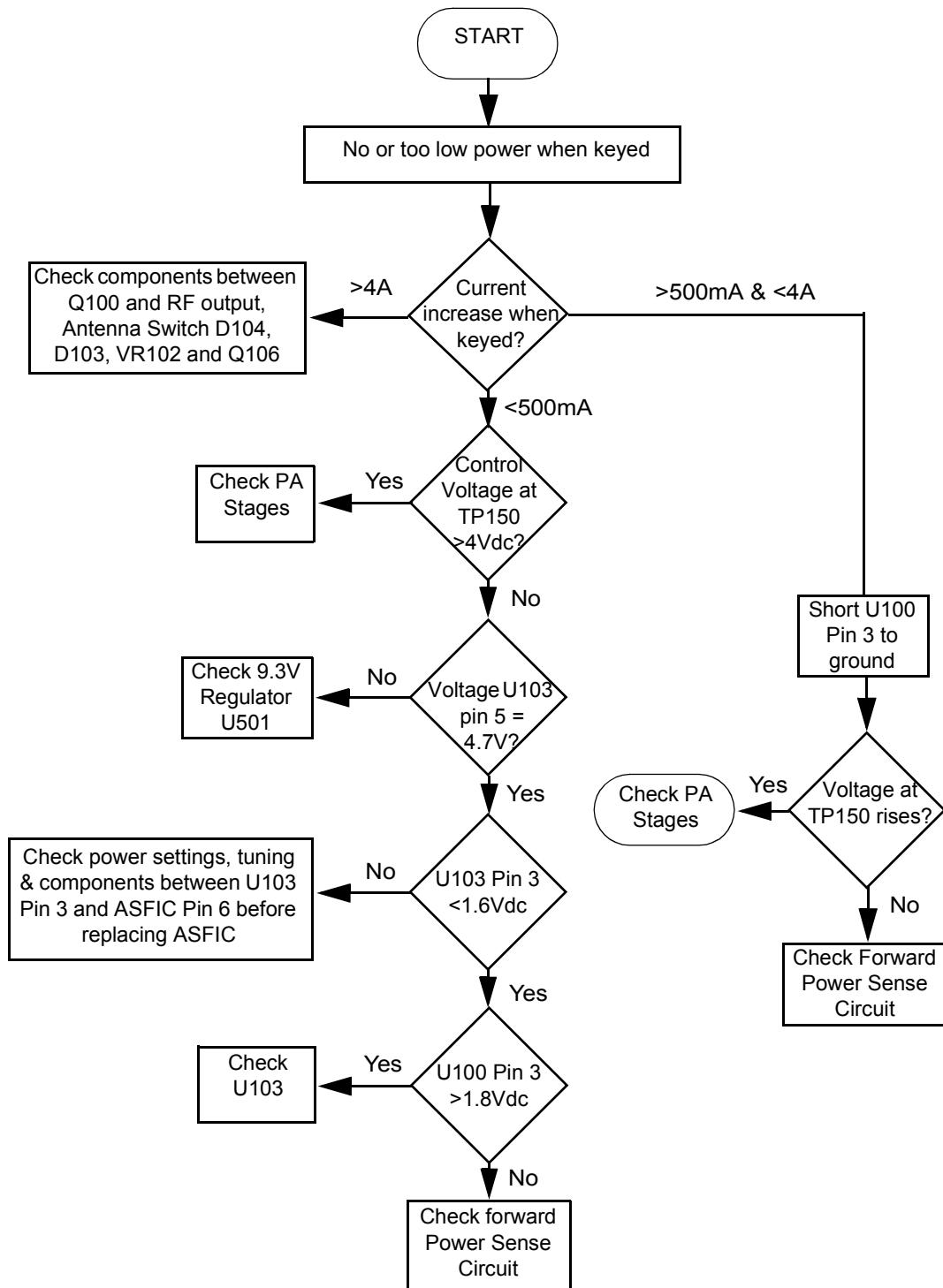

2.1 Troubleshooting Flow Chart for 40W Transmitter (Sheet 2 of 3)

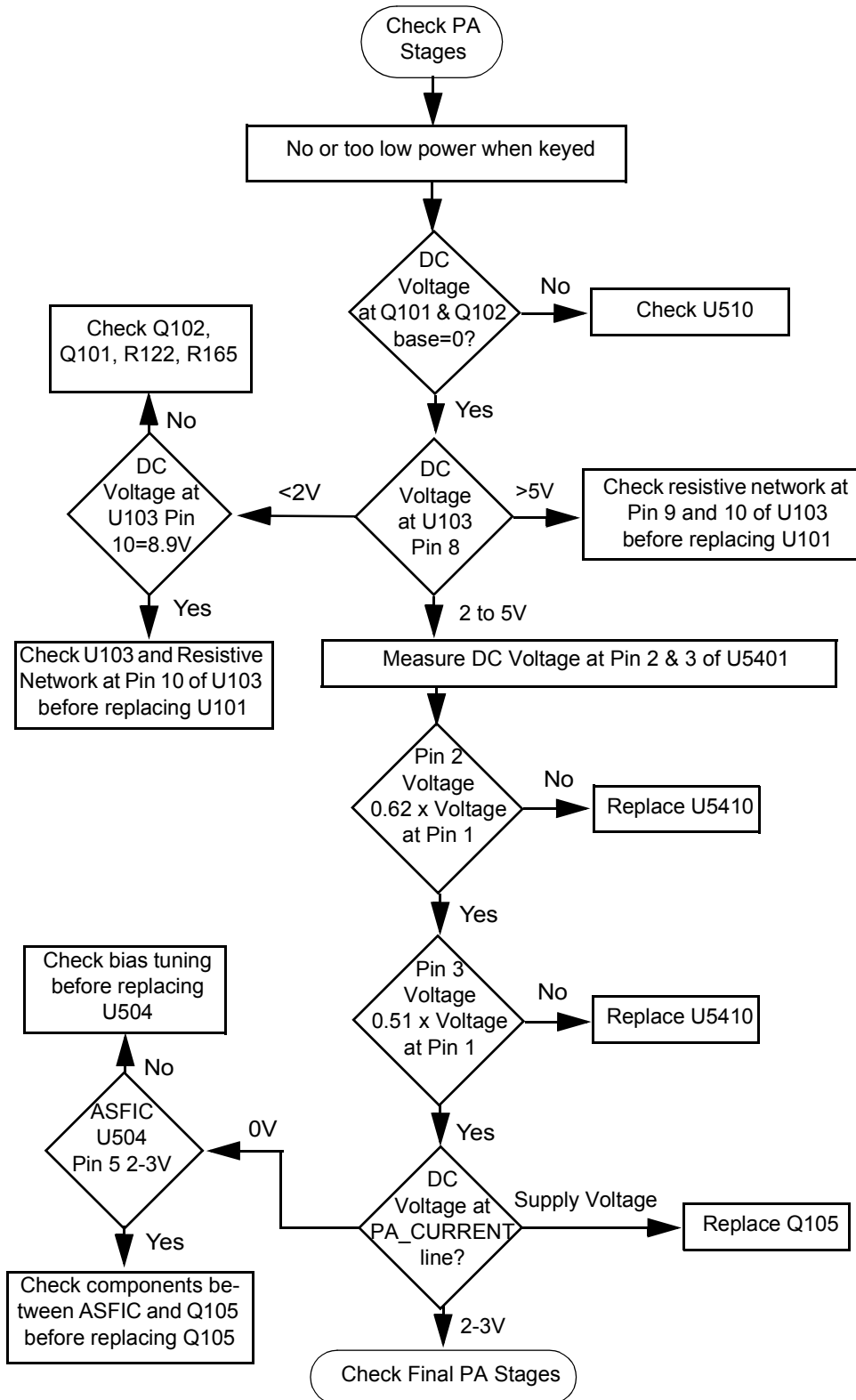

2.2 Troubleshooting Flow Chart for 40W Transmitter (Sheet 3 of 3)

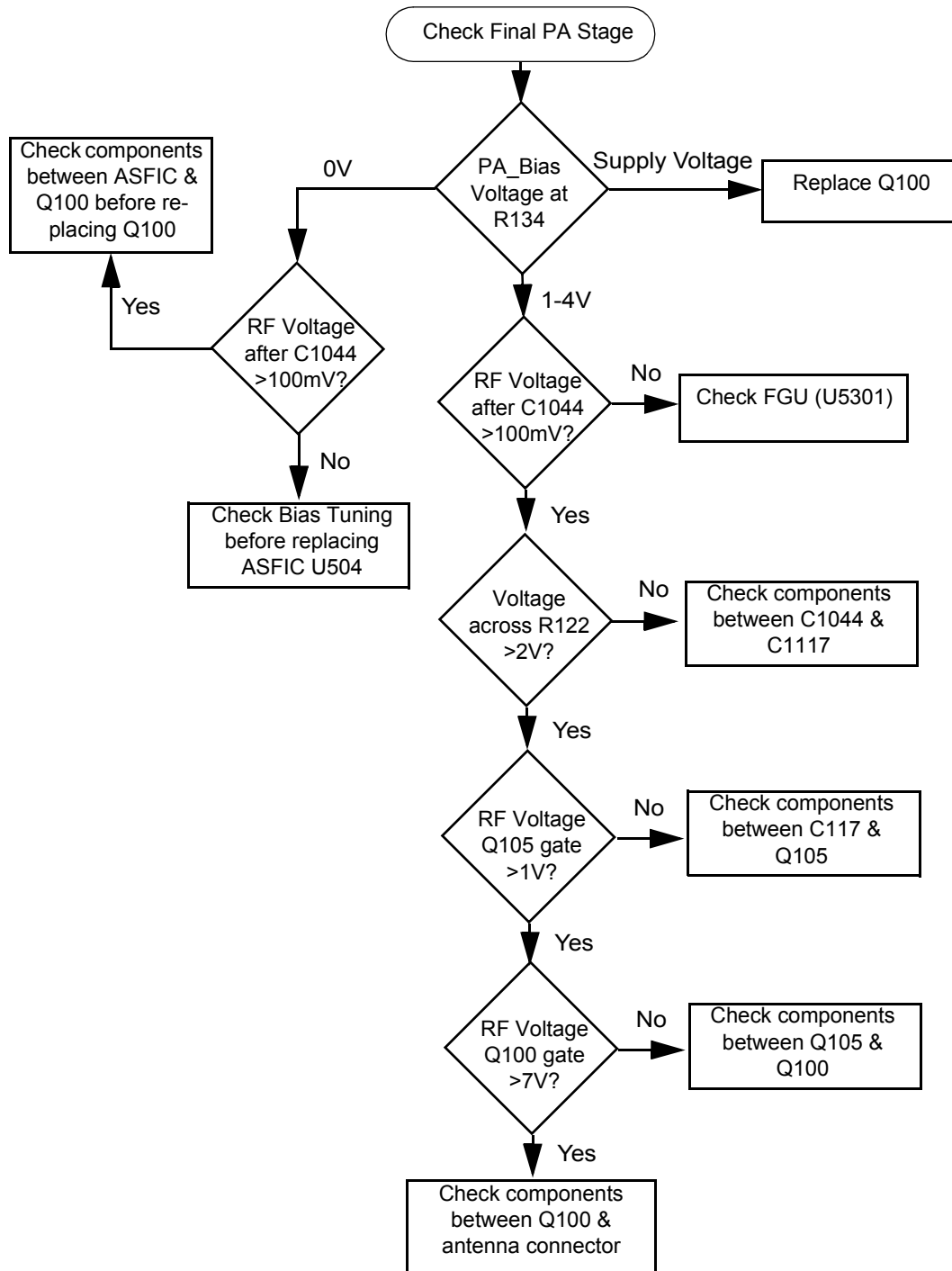

3.0 Troubleshooting Flow Chart for Synthesizer

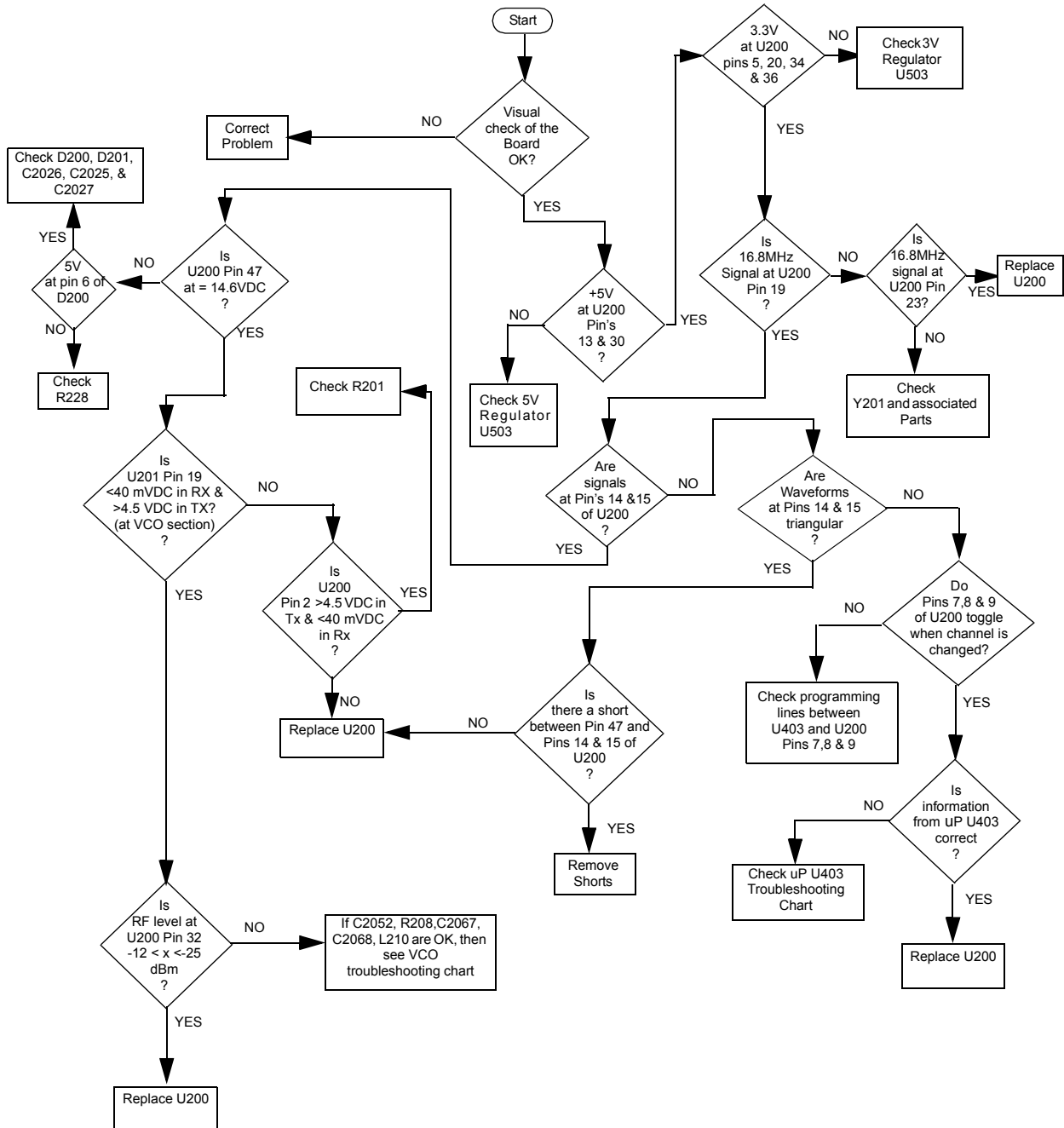

4.0 Troubleshooting Flow Chart for VCO

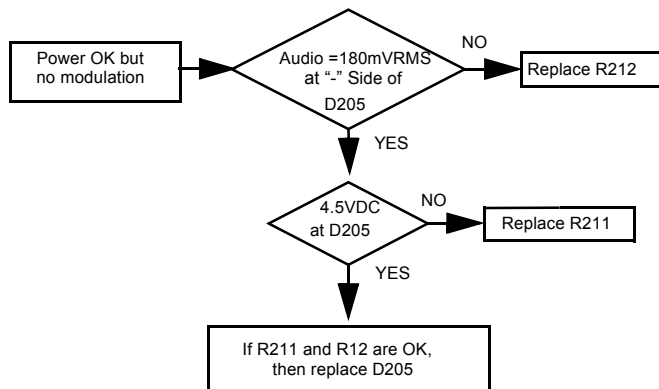
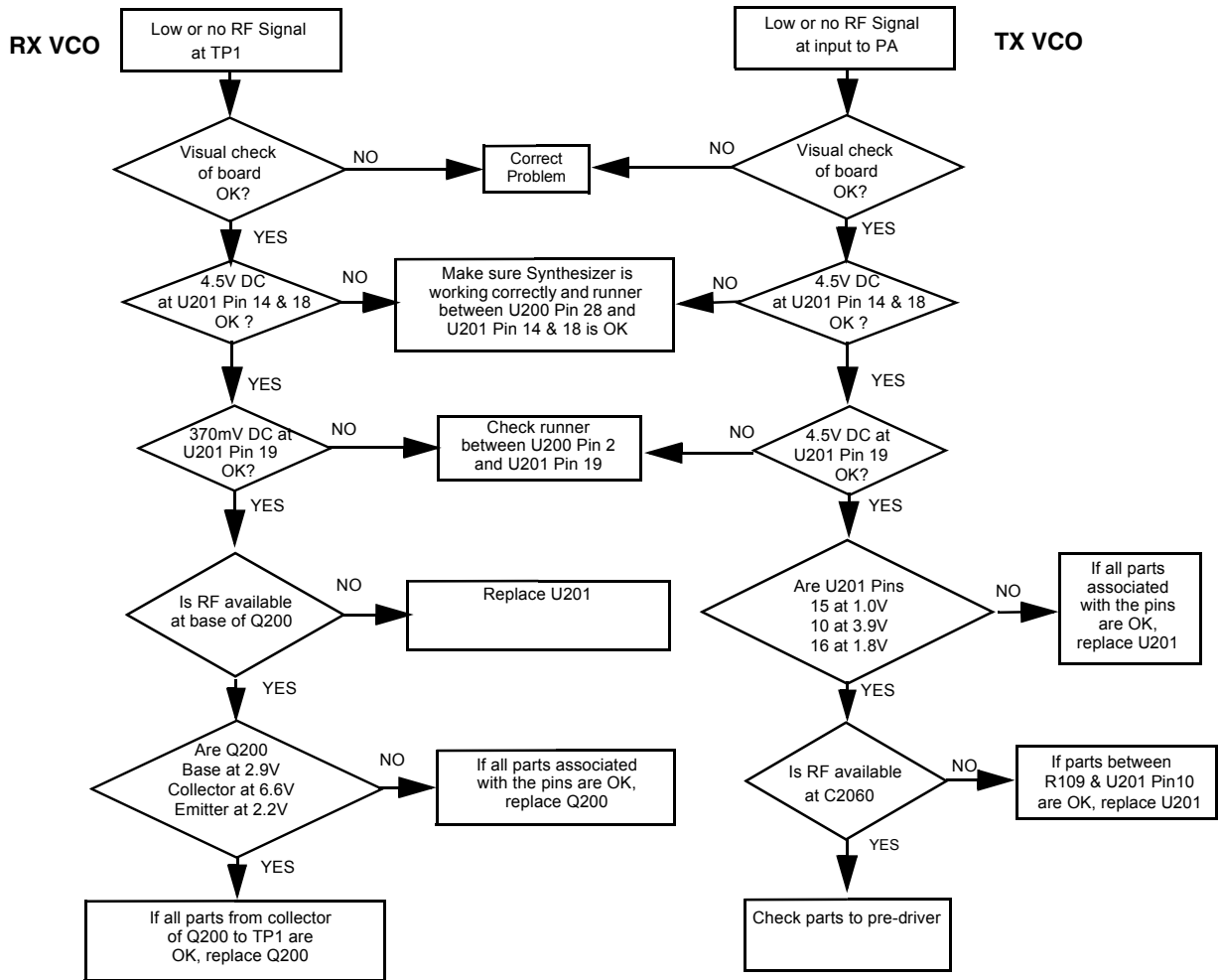

5.0 Troubleshooting Flow Chart for DC Supply (1 of 2)

Since the failure of a critical voltage supply might cause the radio to automatically power down, supply voltages should first be probed with a multimeter. If all the board voltages are absent, then the voltage test point should be retested using a rising-edge-triggered oscilloscope. If the voltage is still absent, then another voltage should be tested using the oscilloscope. If that voltage is present, then the original voltage supply in question is defective and requires investigation of associated circuitry.

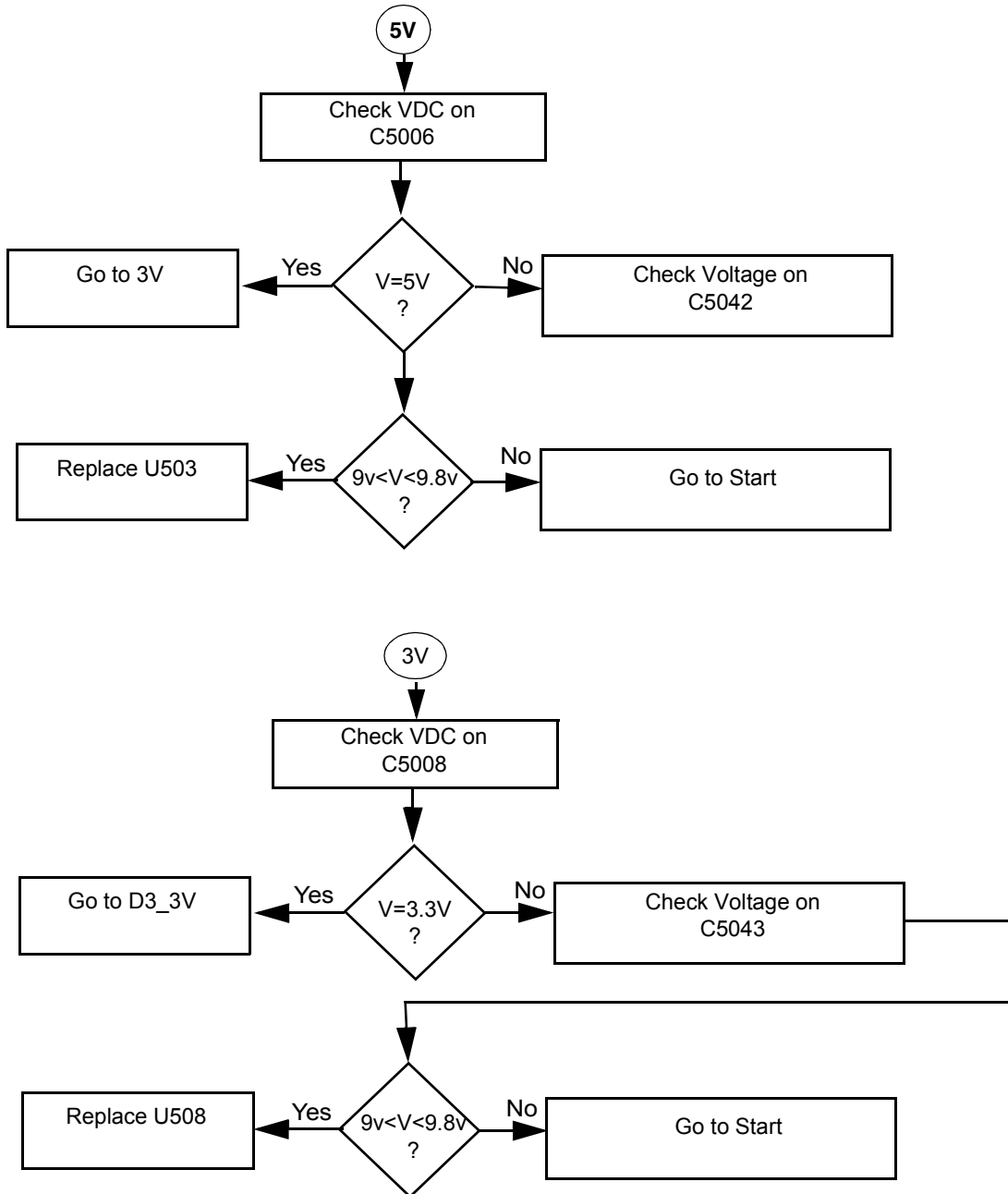

5.1 Troubleshooting Flow Chart for DC Supply (2 of 2)

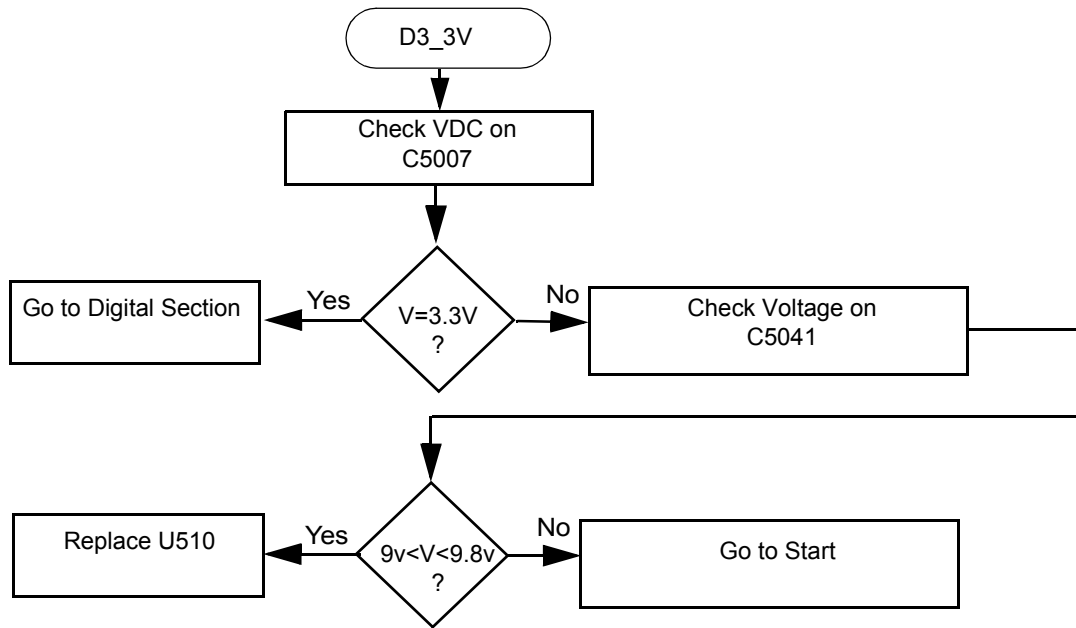

Chapter 4

UHF2 PCB/ SCHEMATICS/ PARTS LISTS

1.0 Allocation of Schematics and Circuit Boards

1.1 UHF2 and Controller Circuits

The UHF circuits are contained on the printed circuit board (PCB) which also contains the Controller circuits. This Chapter shows the schematics for both the UHF circuits and the Controller circuits. The PCB component layouts and the Parts Lists in this Chapter show both the Controller and UHF circuit components. The UHF and Controller schematics and the related PCB and parts list are shown in the tables below.

Table 4-1 UHF2 25-40W Diagrams and Parts Lists

PCB : 8486577Z01 Main Board Top Side 8486577Z01 Main Board Bottom Side	Page4-4 Page4-5
SCHEMATICS Main Circuit Transmitter Synthesiser and VCO Receiver Front and Back End DC and Audio Ccts Microprocessor and Controller Ccts Power Control Cct	Page4-6/Page 4-7 Page 4-8/Page 4-9 Page 4-10/Page 4-11 Page 4-12/Page 4-13 Page 4-14/Page 4-15 Page 4-16/Page 4-17 Page 4-18
Parts List 8486577Z01	Page 4-19
Controller version is T1	

THIS PAGE INTENTIONALLY LEFT BLANK

2.0 UHF2 25-40W PCB 8486577Z01 / Schematics

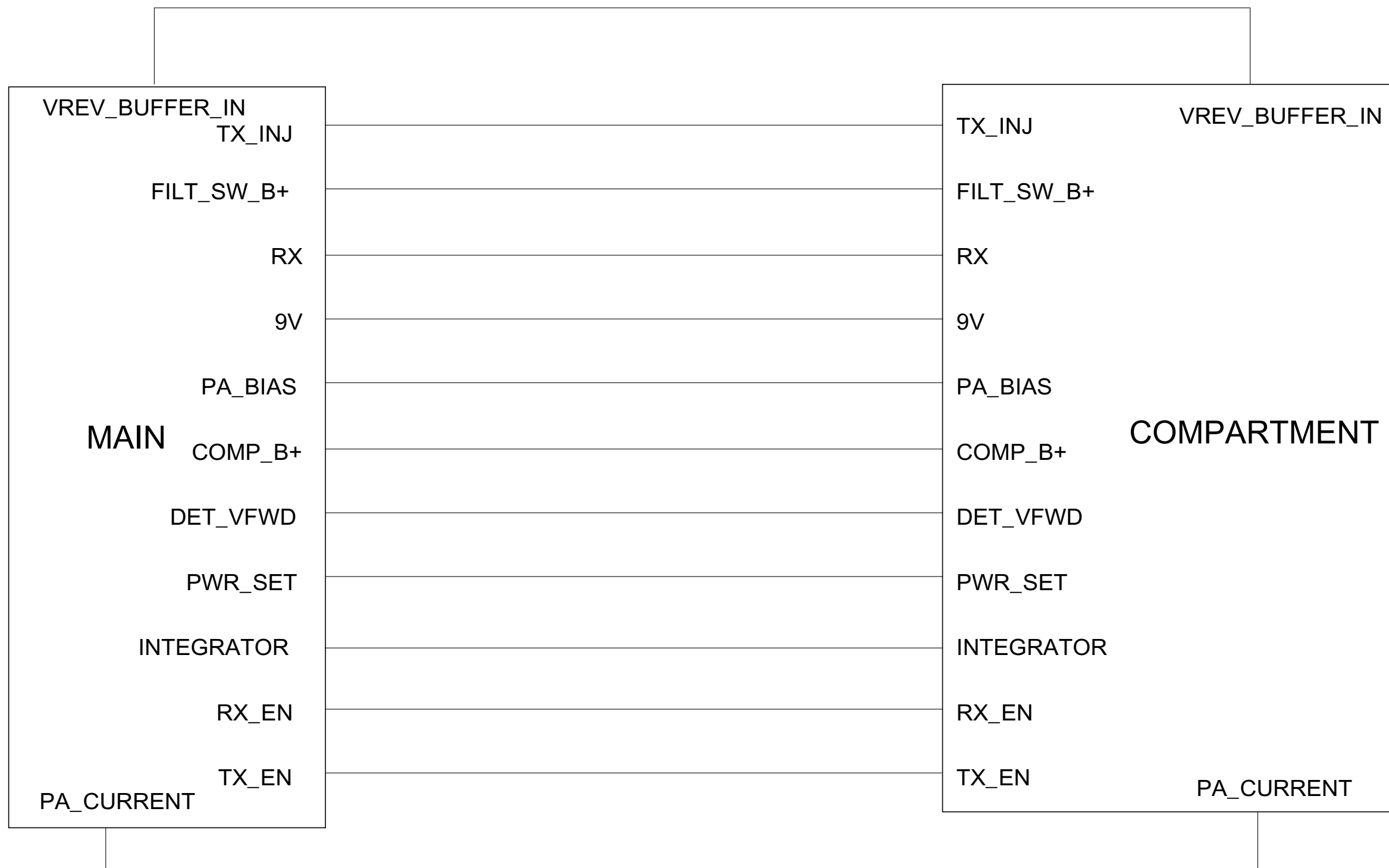

UHF 2 Interconnection between Main Board and Power Amplifier Compartment

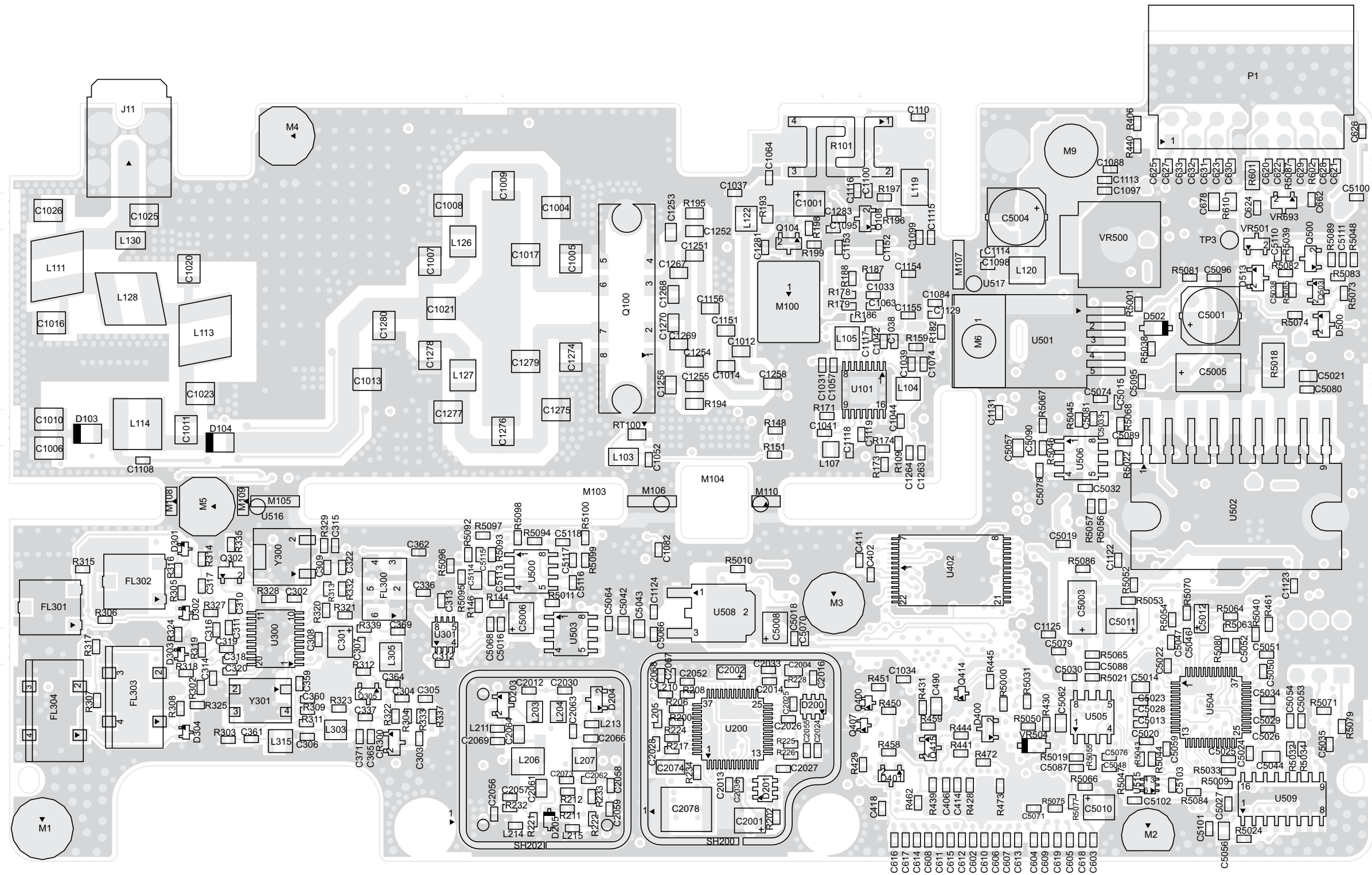

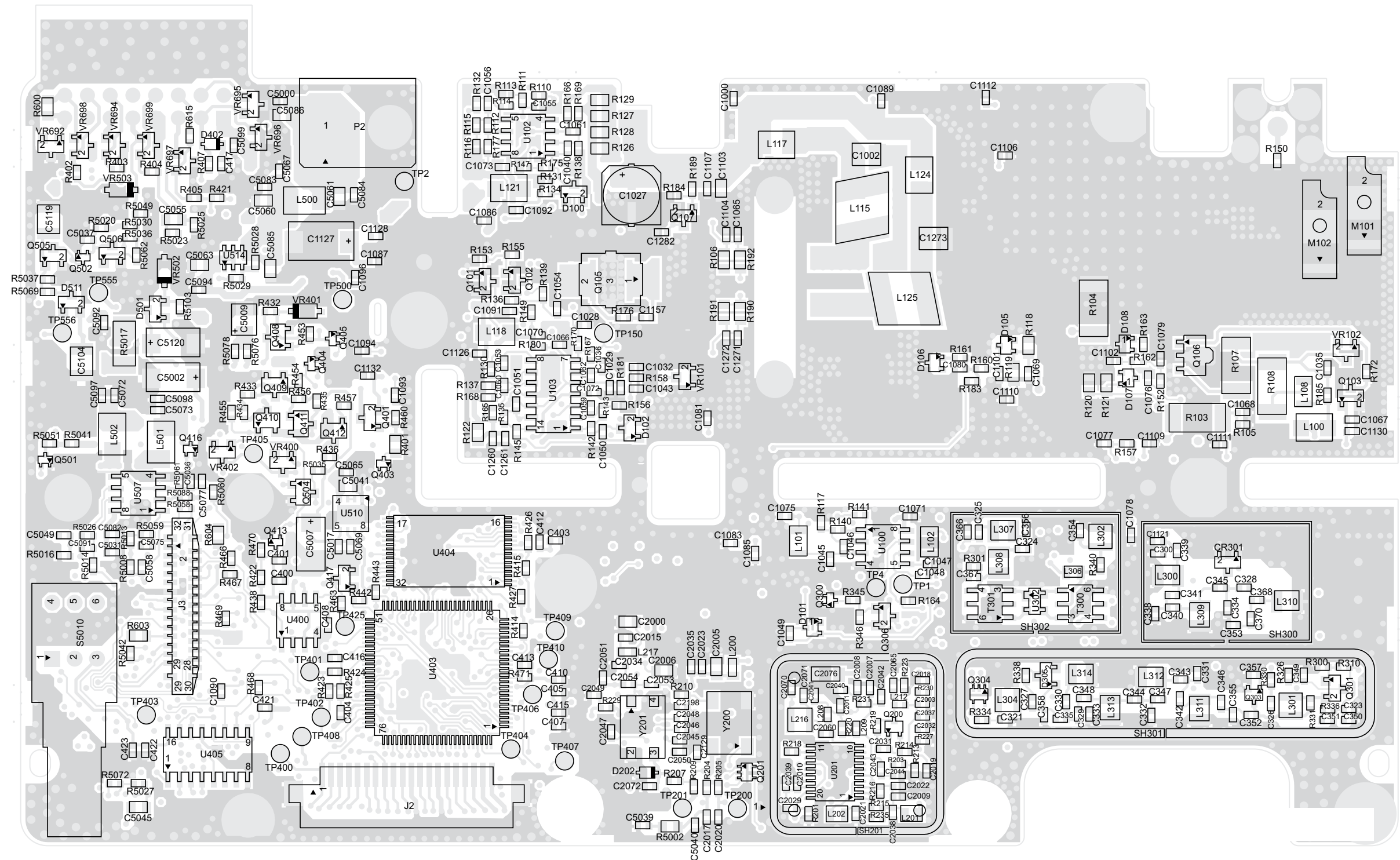

UHF2 (438-470MHz) 25-40W 8486577Z01

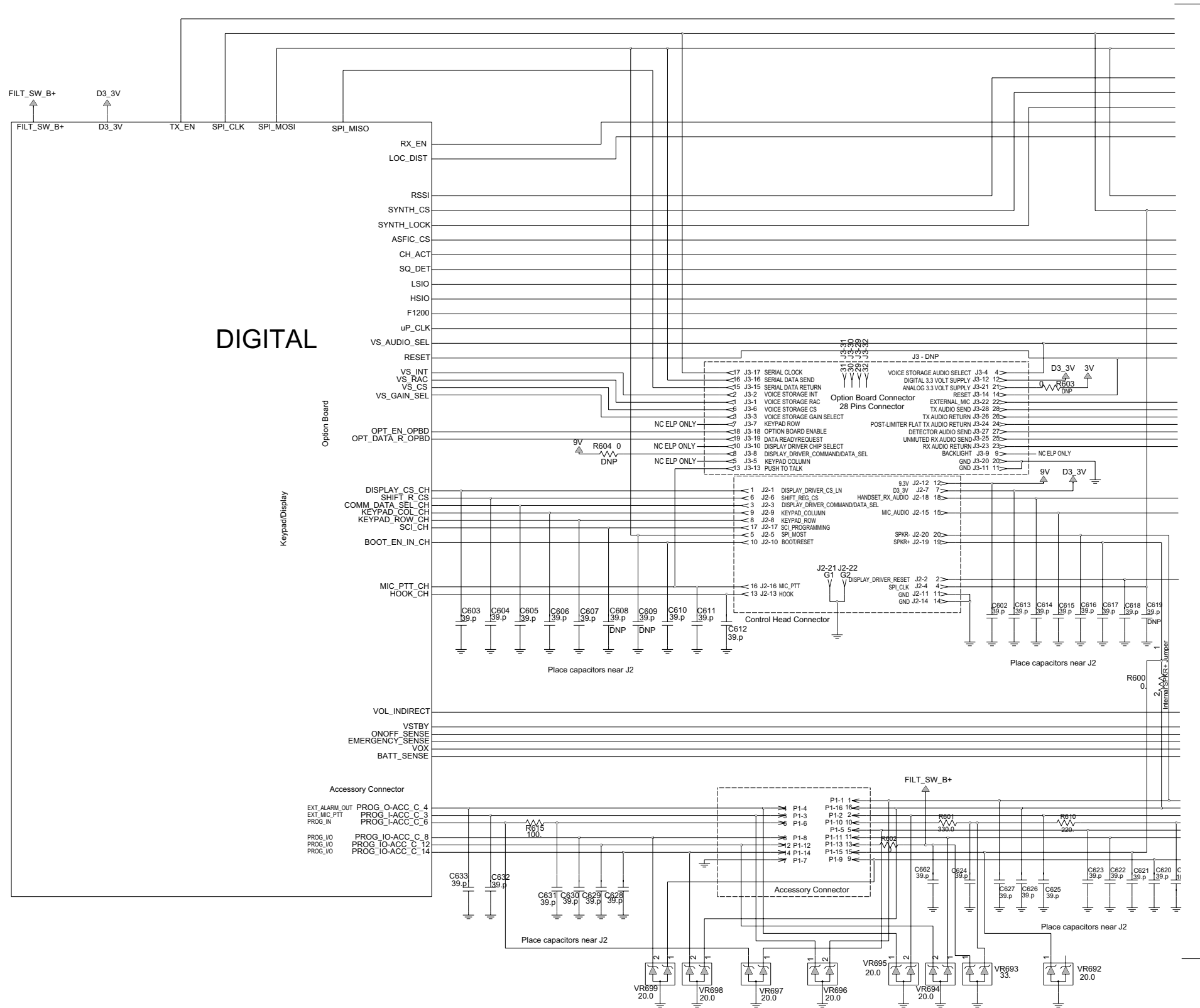

UHF2 (438-470MHz) Main Circuit (Sht 1 of 2)

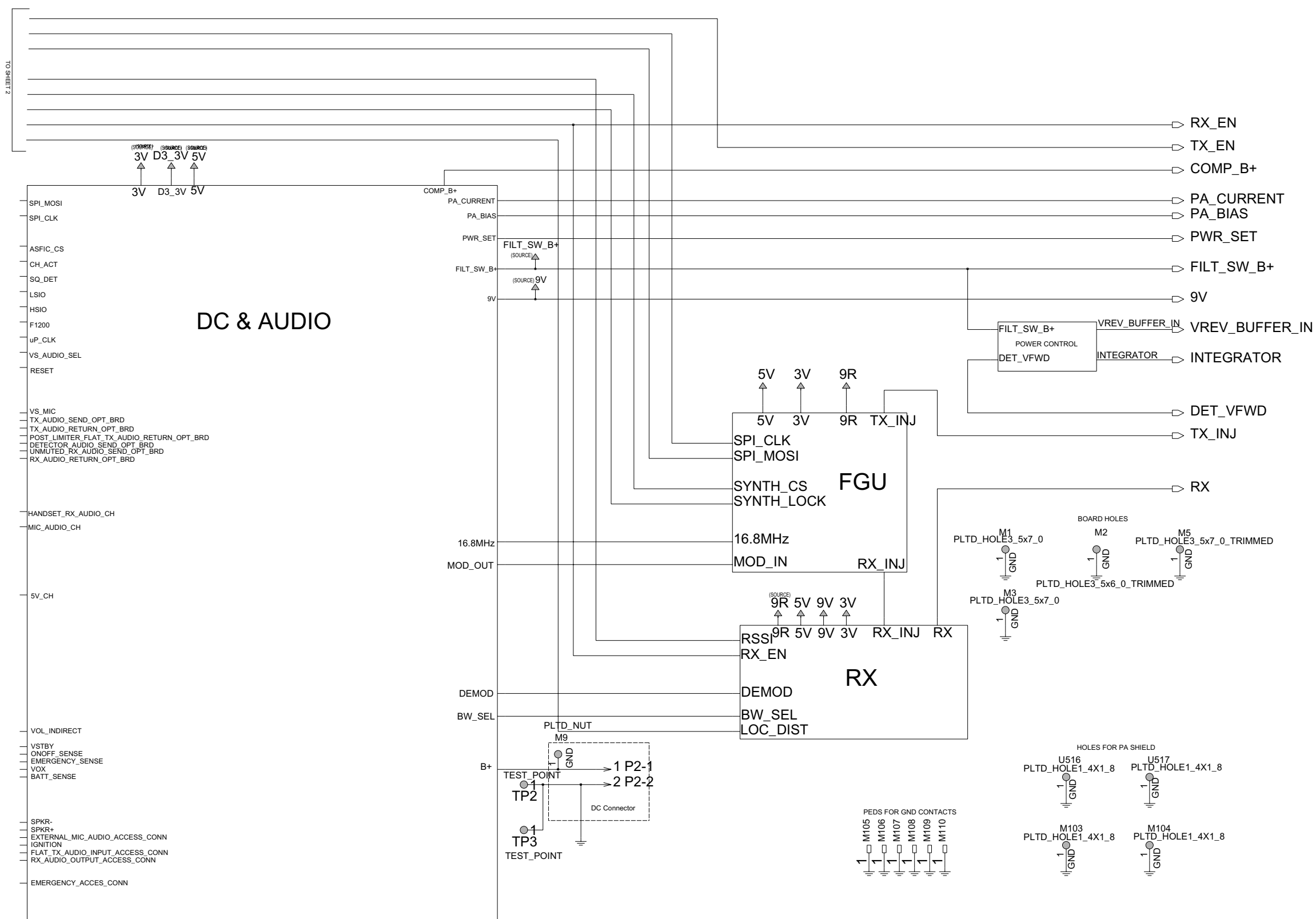

UHF2 (438-470MHz) Main Circuit (Sht 2 of 2)

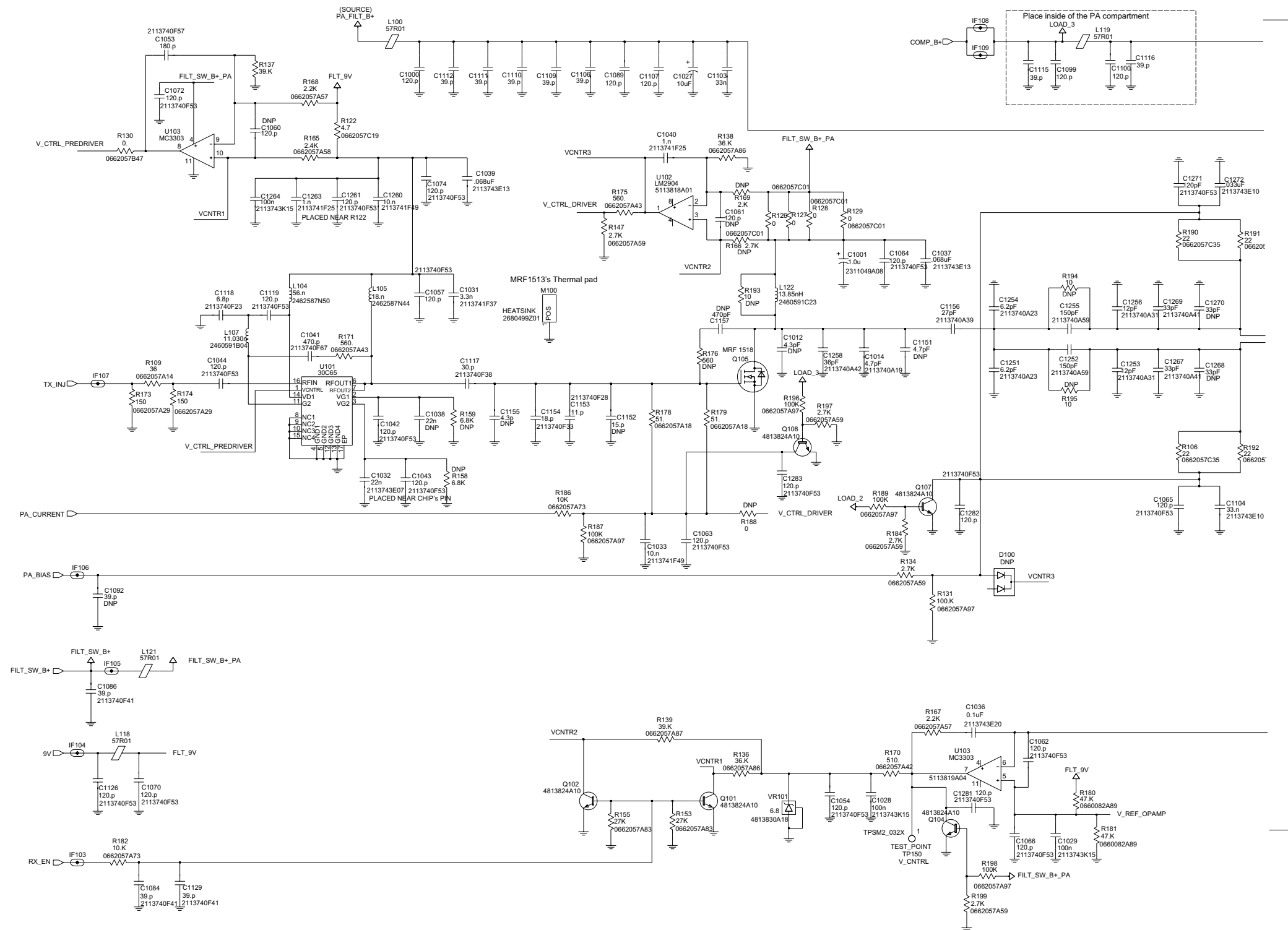

UHF2 (438-470MHz) Transmitter (Sht 1 of 2)

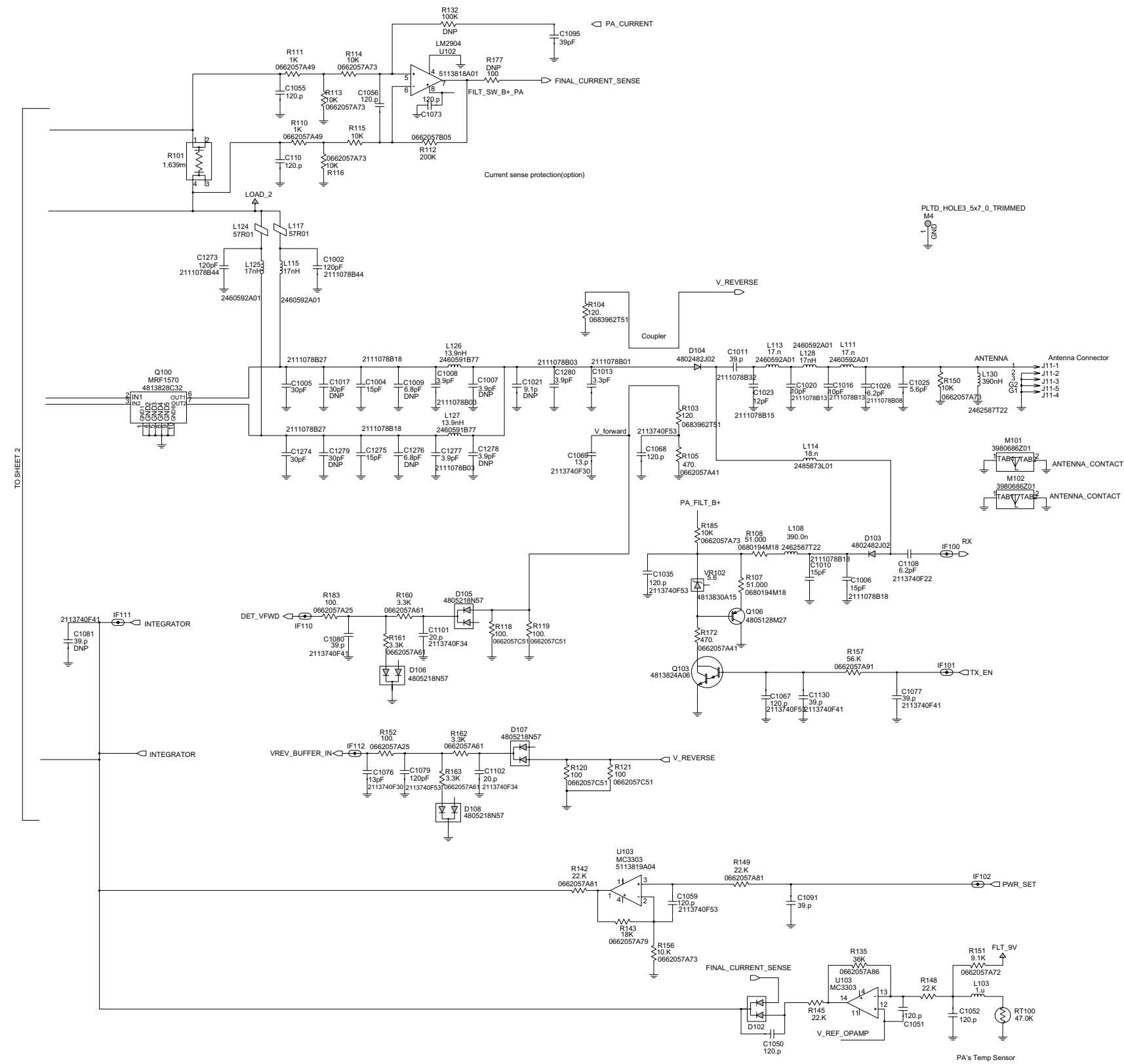

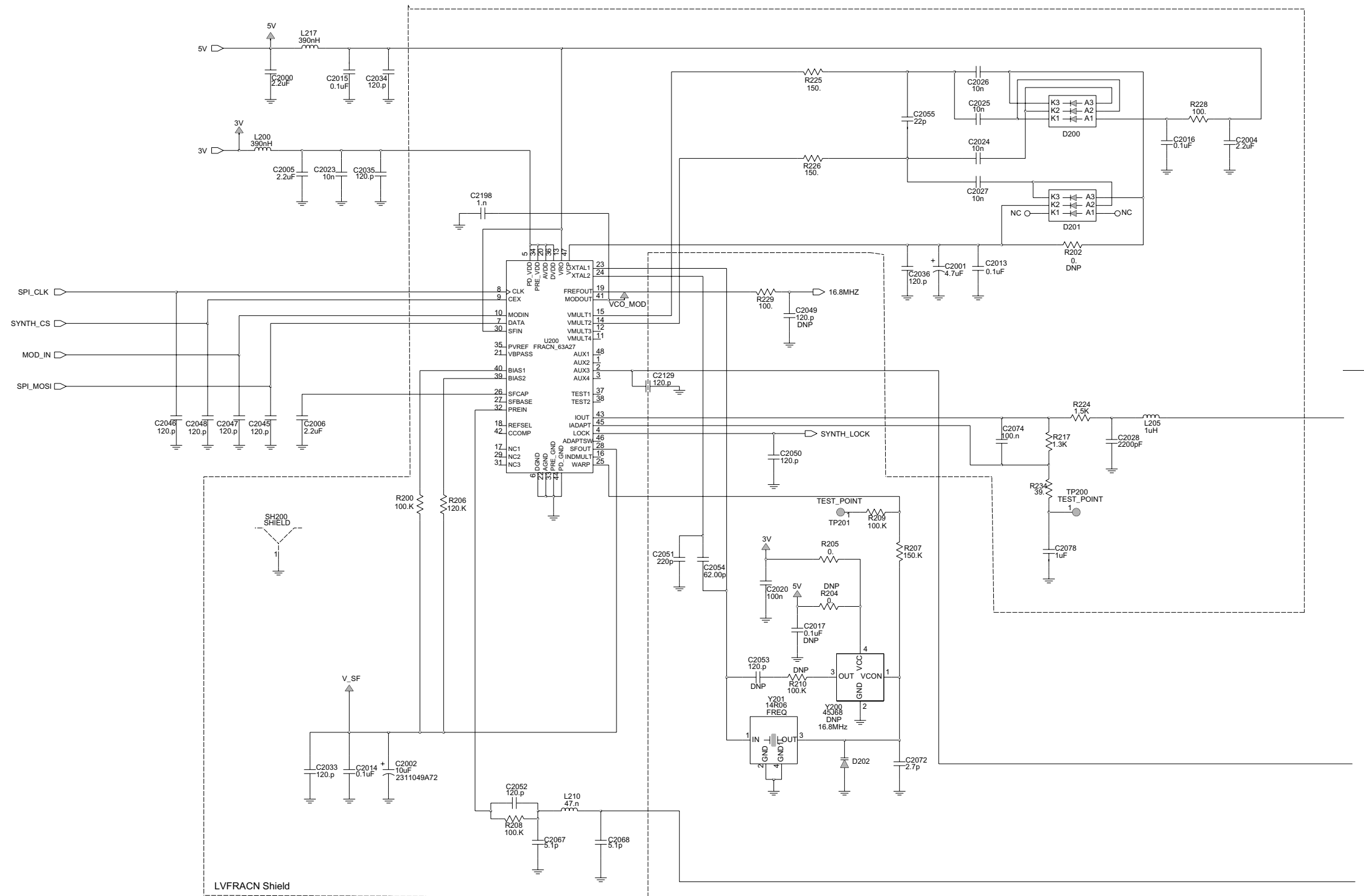

UHF2 (438-470MHz) Synthesiser and VCO (Sht 1 of 2)

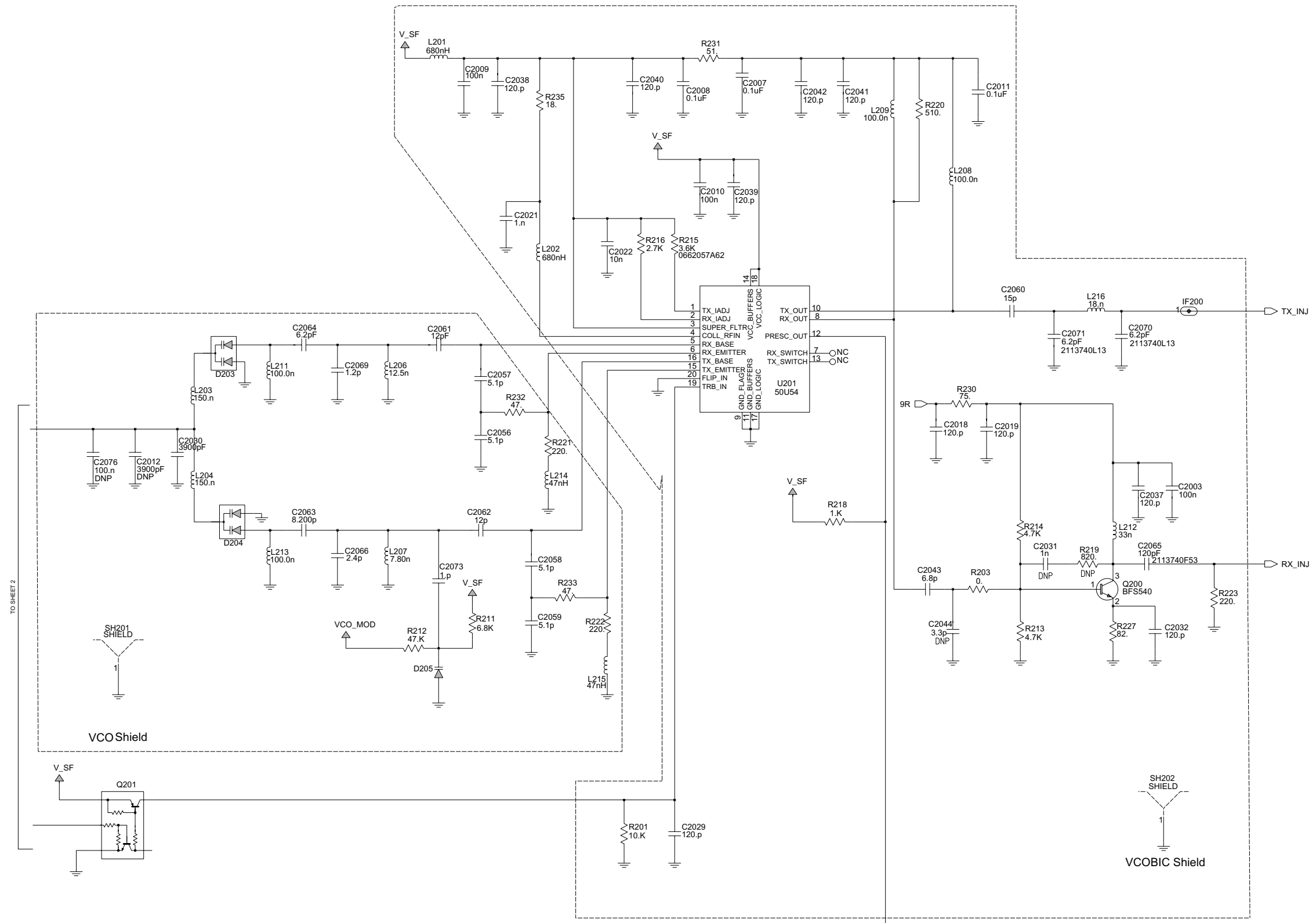

UHF2 (438-470MHz) Synthesiser and VCO (Sht 2 of 2)

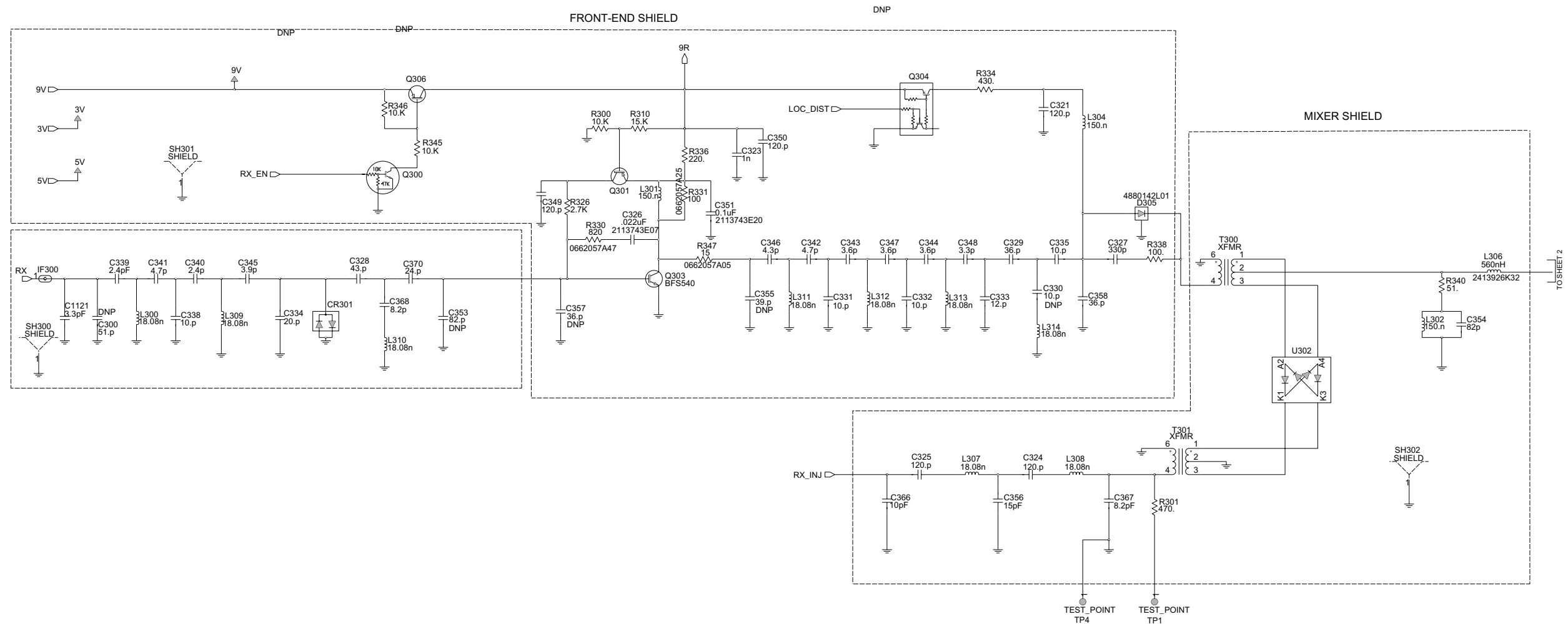

UHF2 (438-470MHz) Receiver Front and Back End (Sht 1 of 2)

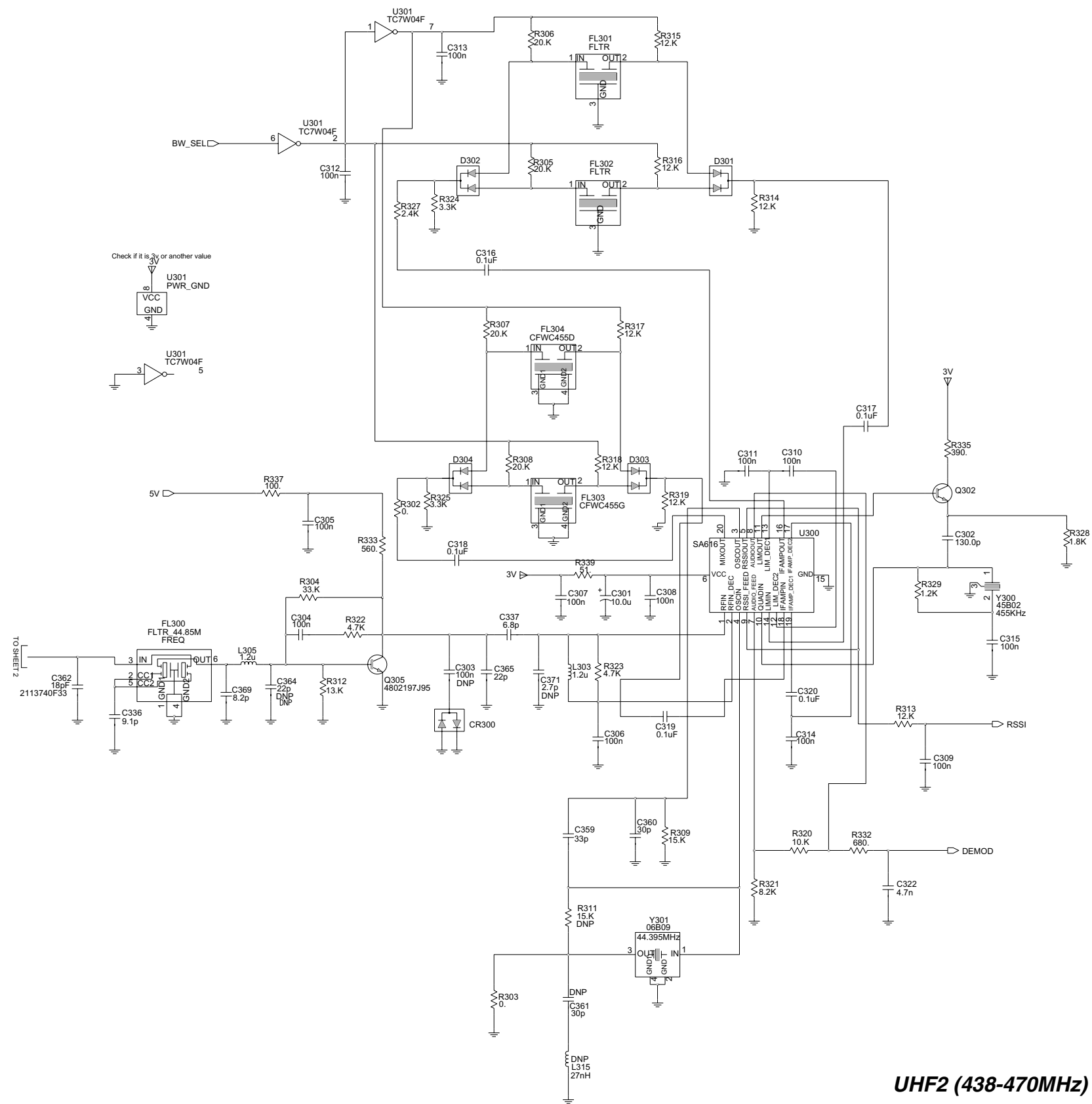

UHF2 (438-470MHz) Receiver Front and Back End (Sht 2 of 2)

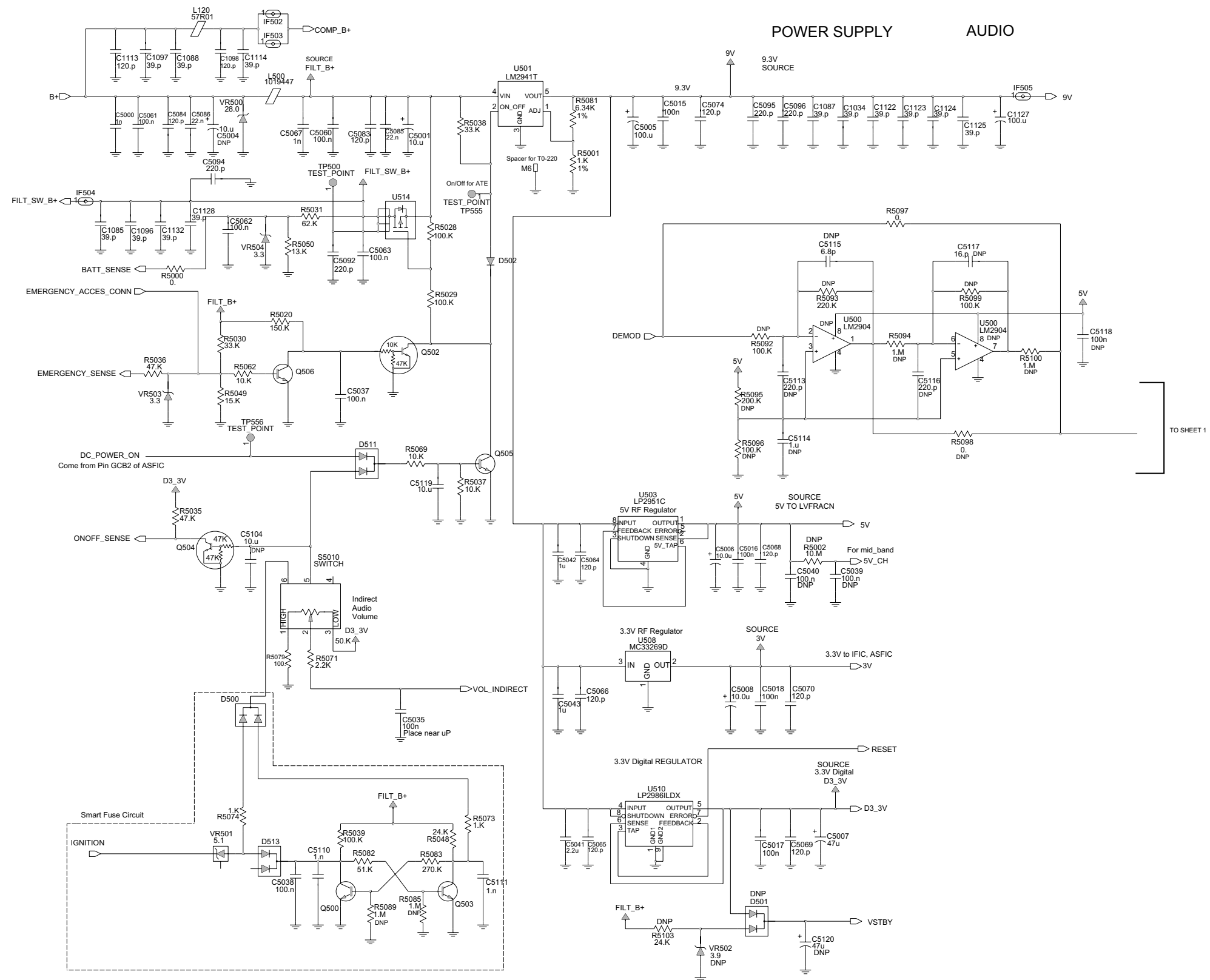

UHF2 (438-470MHz) DC and Audio Circuits (Sht 1 of 2)

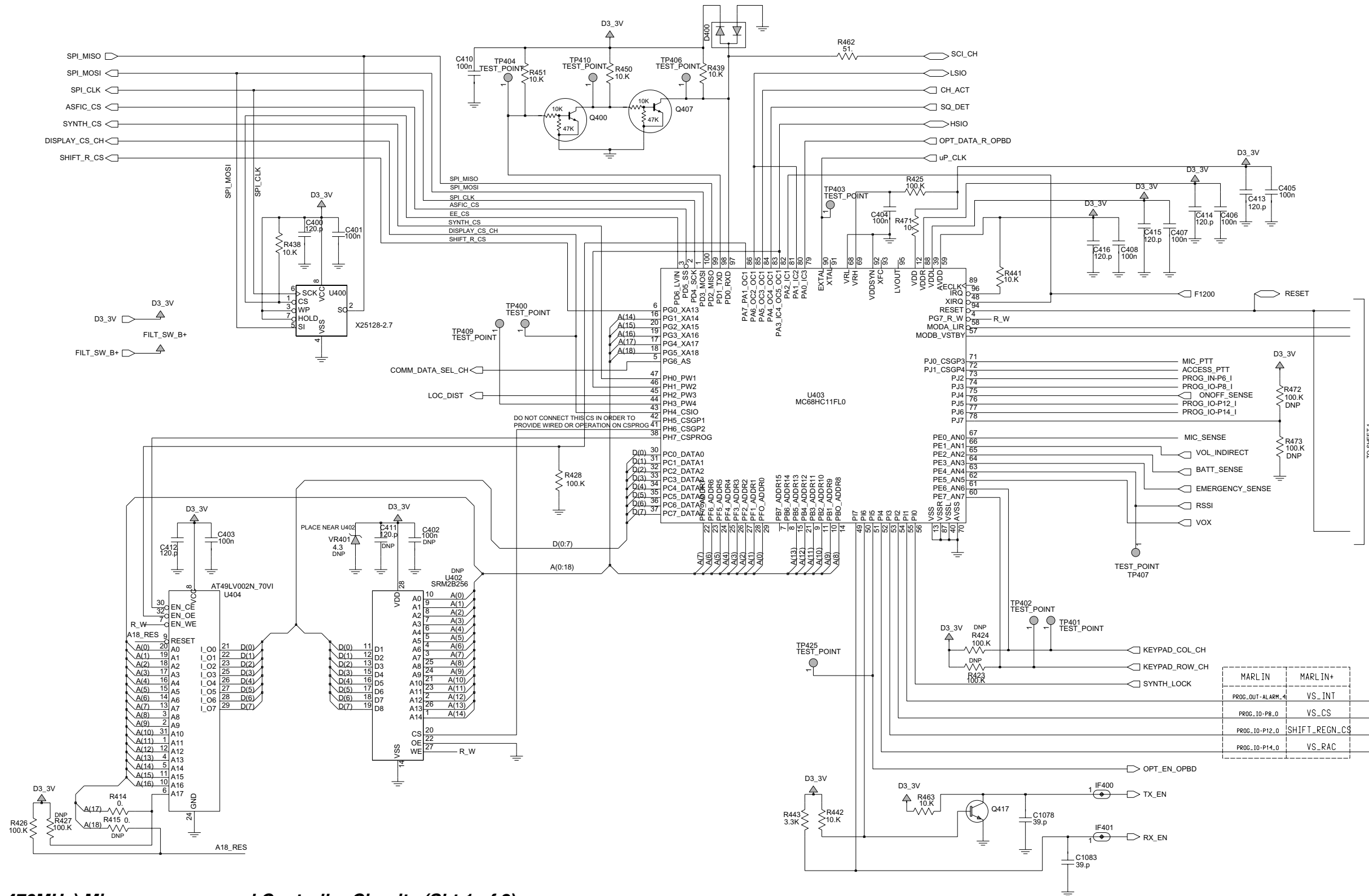

UHF2 (438-470MHz) Microprocessor and Controller Circuits (Sht 1 of 2)

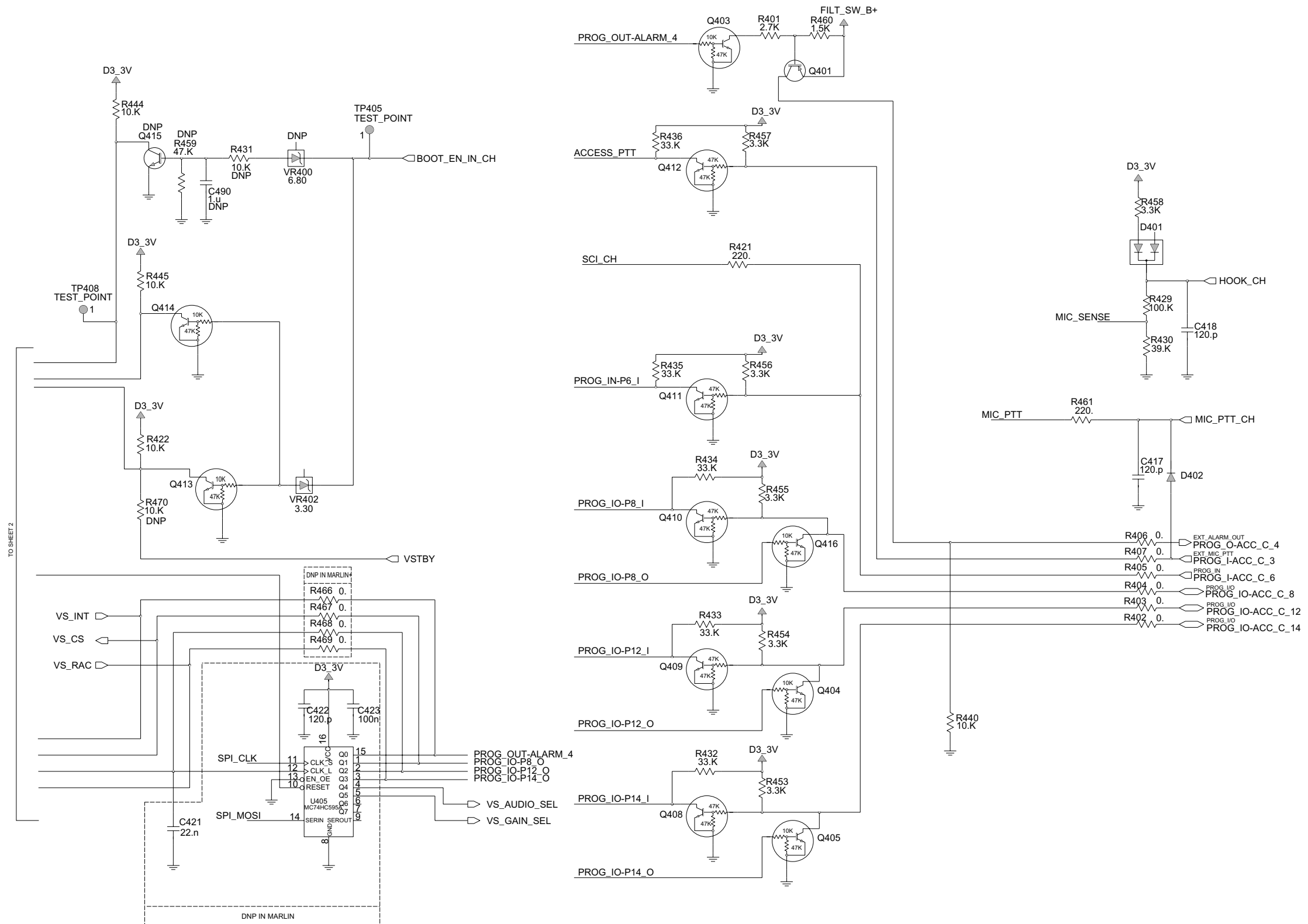

UHF2 (438-470MHz) Microprocessor and Controller Circuits (Sht 2 of 2)

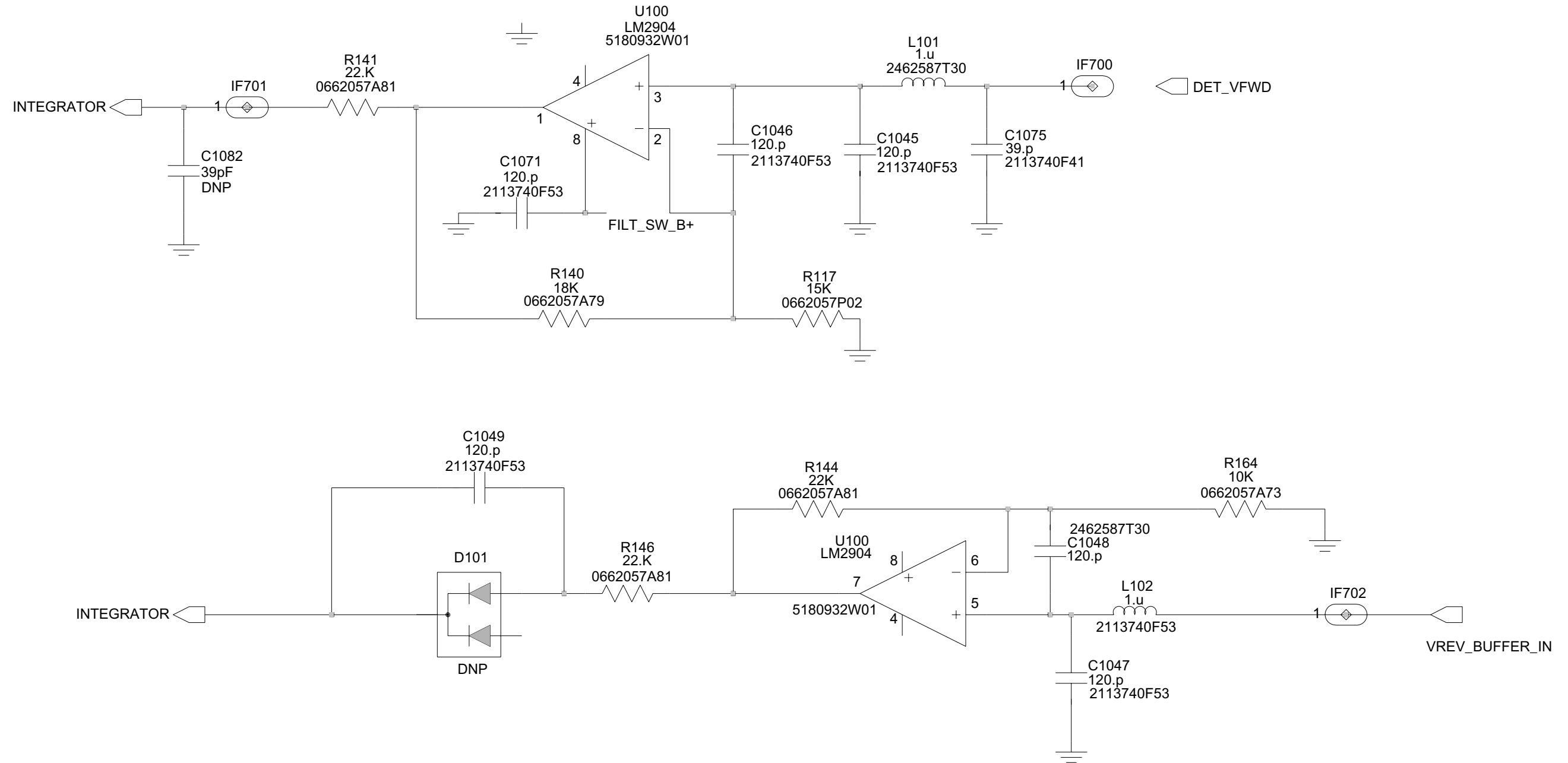

UHF2 (438-470MHz) Power Control Circuit

2.1 UHF2 PCB 8486577Z01 Parts List 40W

Circuit Ref.	Motorola Part No.	Description
C1000	2113740F53	CAP CHIP REEL CL1 +/-30 120
C1001	2311049A08	KEMET CAPS
C1002	2111078B44	CAP CHIP RF 120 5 NPO 100V
C1004	2111078B18	CAP CHIP RF 15 5 NPO 100V
C1005	2111078B27	CAP CHIP RF 30 5 NPO 100V
C1006	2111078B18	CAP CHIP RF 15 5 NPO 100V
C1007	NOT PLACED	GCAM DUMMY PART NUMBER
C1008	2111078B03	CAP CHIP RF 3.9.25 NPO 100V
C1009	NOT PLACED	GCAM DUMMY PART NUMBER
C1010	2111078B18	CAP CHIP RF 15 5 NPO 100V
C1011	2111078B32	CAP ALT E12
C1012	NOT PLACED	GCAM DUMMY PART NUMBER
C1013	2111078B01	CAP CHIP RF 3.3 .25 NPO 100V
C1014	2113740A19	CAP CHIP REEL CL1 +/-30 4.7
C1016	2111078B13	CAP ALT E16
C1017	NOT PLACED	GCAM DUMMY PART NUMBER
C1020	2111078B13	CAP ALT E16
C1021	NOT PLACED	GCAM DUMMY PART NUMBER
C1023	2111078B15	CAP CHIP RF 12 5 NPO 100V
C1025	NOT PLACED	GCAM DUMMY PART NUMBER

Circuit Ref.	Motorola Part No.	Description
C1026	2111078B08	CAP CHIP RF 6.2 .25NPO 100V
C1027	2389289U01	10UF 50V 20% ALUMINUM SMD
C1028	2113743K15	CHIP CAP, CER 0.1UF
C1029	2113743K15	CHIP CAP, CER 0.1UF
C1031	2113741F37	CAP CHIP CL2 X7R REEL 3300
C1032	2113743E07	CER CHIP CAP .022UF
C1033	2113741F49	CAP CHIP CL2 X7R REEL 10000
C1034	2113740F41	CAP CHIP REEL CL1 +/-30 39
C1035	2113740F53	CAP CHIP REEL CL1 +/-30 120
C1036	2113743E20	CAP CHIP. 10 UF 10%
C1037	2113743E13	CAP CHIP 0.068UF
C1038	NOT PLACED	GCAM DUMMY PART NUMBER
C1039	2113743E13	CAP CHIP 0.068UF
C1040	2113741F25	CAP CHIP CL2 X7R REEL 1000
C1041	2113740F67	CAP CHIP CL1 +/-30 470 5%
C1042	2113740F53	CAP CHIP REEL CL1 +/-30 120
C1043	2113740F53	CAP CHIP REEL CL1 +/-30 120
C1044	2113740F53	CAP CHIP REEL CL1 +/-30 120
C1045	2113740F53	CAP CHIP REEL CL1 +/-30 120
C1046	2113740F53	CAP CHIP REEL CL1 +/-30 120
C1047	2113740F53	CAP CHIP REEL CL1 +/-30 120
C1048	2113740F53	CAP CHIP REEL CL1 +/-30 120

Circuit Ref.	Motorola Part No.	Description
C1049	2113740F53	CAP CHIP REEL CL1 +/-30 120
C1050	2113740F53	CAP CHIP REEL CL1 +/-30 120
C1051	2113740F53	CAP CHIP REEL CL1 +/-30 120
C1052	2113740F53	CAP CHIP REEL CL1 +/-30 120
C1053	2113740F57	CAP CHIP REEL CL1 +/-30 180
C1054	2113740F53	CAP CHIP REEL CL1 +/-30 120
C1055	2113740F53	CAP CHIP REEL CL1 +/-30 120
C1056	2113740F53	CAP CHIP REEL CL1 +/-30 120
C1057	2113740F53	CAP CHIP REEL CL1 +/-30 120
C1059	2113740F53	CAP CHIP REEL CL1 +/-30 120
C1060	NOT PLACED	GCAM DUMMY PART NUMBER
C1061	NOT PLACED	GCAM DUMMY PART NUMBER
C1062	2113740F53	CAP CHIP REEL CL1 +/-30 120
C1063	2113740F53	CAP CHIP REEL CL1 +/-30 120
C1064	2113740F53	CAP CHIP REEL CL1 +/-30 120
C1065	2113740F53	CAP CHIP REEL CL1 +/-30 120
C1066	2113740F53	CAP CHIP REEL CL1 +/-30 120
C1067	2113740F53	CAP CHIP REEL CL1 +/-30 120
C1068	2113740F53	CAP CHIP REEL CL1 +/-30 120

Circuit Ref.	Motorola Part No.	Description
C1069	2113740F30	CAP CHIP REEL CL1 +/-30 13
C1070	2113740F53	CAP CHIP REEL CL1 +/-30 120
C1071	2113740F53	CAP CHIP REEL CL1 +/-30 120
C1072	2113740F53	CAP CHIP REEL CL1 +/-30 120
C1073	2113740F53	CAP CHIP REEL CL1 +/-30 120
C1074	2113740F53	CAP CHIP REEL CL1 +/-30 120
C1075	2113740F41	CAP CHIP REEL CL1 +/-30 39
C1076	2113740F30	CAP CHIP REEL CL1 +/-30 13
C1077	2113740F41	CAP CHIP REEL CL1 +/-30 39
C1078	2113740F41	CAP CHIP REEL CL1 +/-30 39
C1079	2113740F53	CAP CHIP REEL CL1 +/-30 120
C1080	2113740F41	CAP CHIP REEL CL1 +/-30 39
C1081	NOT PLACED	GCAM DUMMY PART NUMBER
C1082	NOT PLACED	GCAM DUMMY PART NUMBER
C1083	2113740F41	CAP CHIP REEL CL1 +/-30 39
C1084	2113740F41	CAP CHIP REEL CL1 +/-30 39
C1085	2113740F41	CAP CHIP REEL CL1 +/-30 39
C1086	2113740F41	CAP CHIP REEL CL1 +/-30 39
C1087	2113740F41	CAP CHIP REEL CL1 +/-30 39

Circuit Ref.	Motorola Part No.	Description
C1088	2113740F41	CAP CHIP REEL CL1 +/-30 39
C1089	2113740F53	CAP CHIP REEL CL1 +/-30 120
C1090	NOT PLACED	GCAM DUMMY PART NUMBER
C1091	NOT PLACED	GCAM DUMMY PART NUMBER
C1092	NOT PLACED	GCAM DUMMY PART NUMBER
C1093	NOT PLACED	GCAM DUMMY PART NUMBER
C1094	2113740F53	CAP CHIP REEL CL1 +/-30 120
C1095	2113740F41	CAP CHIP REEL CL1 +/-30 39
C1096	2113740F41	CAP CHIP REEL CL1 +/-30 39
C1097	2113740F41	CAP CHIP REEL CL1 +/-30 39
C1098	2113740F53	CAP CHIP REEL CL1 +/-30 120
C1099	2113740F53	CAP CHIP REEL CL1 +/-30 120
C110	2113740F53	CAP CHIP REEL CL1 +/-30 120
C1100	2113740F53	CAP CHIP REEL CL1 +/-30 120
C1101	2113740F34	CAP CHIP REEL CL1 +/-30 20
C1102	2113740F34	CAP CHIP REEL CL1 +/-30 20
C1103	2113741A57	CAP CHIP 33K +/-5% (2160521A31)
C1104	2113743E10	CAP CHIP .033 UF 10% X 7R
C1106	2113740F41	CAP CHIP REEL CL1 +/-30 39
C1107	2113740F53	CAP CHIP REEL CL1 +/-30 120

Circuit Ref.	Motorola Part No.	Description
C1108	2113740F22	CAP CHIP REEL CL1 +/-30 6.2
C1109	2113740F41	CAP CHIP REEL CL1 +/-30 39
C1110	2113740F41	CAP CHIP REEL CL1 +/-30 39
C1111	2113740F41	CAP CHIP REEL CL1 +/-30 39
C1112	2113740F41	CAP CHIP REEL CL1 +/-30 39
C1113	2113740F53	CAP CHIP REEL CL1 +/-30 120
C1114	2113740F41	CAP CHIP REEL CL1 +/-30 39
C1115	2113740F41	CAP CHIP REEL CL1 +/-30 39
C1116	2113740F41	CAP CHIP REEL CL1 +/-30 39
C1117	2113740F38	CAP CHIP REEL CL1 +/-30 30
C1118	2113740F23	CAP CHIP REEL CL1 +/-30 6.8
C1119	2113740F53	CAP CHIP REEL CL1 +/-30 120
C1121	2113740F15	CAP CHIP REEL CL1 +/-30 3.3
C1122	2113740F41	CAP CHIP REEL CL1 +/-30 39
C1123	2113740F41	CAP CHIP REEL CL1 +/-30 39
C1124	2113740F41	CAP CHIP REEL CL1 +/-30 39
C1125	2113740F41	CAP CHIP REEL CL1 +/-30 39
C1126	2113740F53	CAP CHIP REEL CL1 +/-30 120
C1127	2360567A03	CAP TANTALUM
C1128	2113740F41	CAP CHIP REEL CL1 +/-30 39

Circuit Ref.	Motorola Part No.	Description
C1129	2113740F41	CAP CHIP REEL CL1 +/-30 39
C1130	2113740F41	CAP CHIP REEL CL1 +/-30 39
C1131	NOT PLACED	GCAM DUMMY PART NUMBER
C1132	2113740F41	CAP CHIP REEL CL1 +/-30 39
C1151	NOT PLACED	GCAM DUMMY PART NUMBER
C1152	NOT PLACED	GCAM DUMMY PART NUMBER
C1153	2113740F28	CAP CHIP REEL CL1 +/-30 11
C1154	2113740F33	CAP CHIP REEL CL1 +/-30 18
C1155	NOT PLACED	GCAM DUMMY PART NUMBER
C1156	2113740A39	CAP CHIP REEL CL1 +/-30 27
C1157	NOT PLACED	GCAM DUMMY PART NUMBER
C1251	2113740A23	CAP CHIP REEL CL1 +/-30 6.2
C1252	2113740A59	CHIP CAPACITORS 150PF +/-30%
C1253	2113740A31	CAP CHIP REEL CL1 +/-30 12
C1254	2113740A23	CAP CHIP REEL CL1 +/-30 6.2
C1255	2113740A59	CHIP CAPACITORS 150PF +/-30%
C1256	2113740A31	CAP CHIP REEL CL1 +/-30 12
C1258	2113740A42	CAP CHIP REEL CL1 +/-30 36
C1260	2113741F49	CAP CHIP CL2 X7R REEL 10000

Circuit Ref.	Motorola Part No.	Description
C1261	2113740F53	CAP CHIP REEL CL1 +/-30 120
C1263	2113741F25	CAP CHIP CL2 X7R REEL 1000
C1264	2113743K15	CHIP CAP, CER 0.1UF
C1267	2113740A41	CAP CHIP REEL CL1 +/-30 33
C1268	NOT PLACED	GCAM DUMMY PART NUMBER
C1269	2113740A41	CAP CHIP REEL CL1 +/-30 33
C1270	NOT PLACED	GCAM DUMMY PART NUMBER
C1271	2113740F53	CAP CHIP REEL CL1 +/-30 120
C1272	2113743E10	CAP CHIP .033 UF 10% X 7R
C1273	2111078B44	CAP CHIP RF 120 5 NPO 100V
C1274	2111078B27	CAP CHIP RF 30 5 NPO 100V
C1275	2111078B18	CAP CHIP RF 15 5 NPO 100V
C1276	NOT PLACED	GCAM DUMMY PART NUMBER
C1277	2111078B03	CAP CHIP RF 3.9.25 NPO 100V
C1278	NOT PLACED	GCAM DUMMY PART NUMBER
C1279	NOT PLACED	GCAM DUMMY PART NUMBER
C1280	2111078B03	CAP CHIP RF 3.9.25 NPO 100V
C1281	2113740F53	CAP CHIP REEL CL1 +/-30 120
C1282	2113740F53	CAP CHIP REEL CL1 +/-30 120
C1283	2113740F53	CAP CHIP REEL CL1 +/-30 120

Circuit Ref.	Motorola Part No.	Description
C2000	2113743F18	CAP CHIP 2.2 UF 16V +80-20%
C2001	2311049J11	CAPACITOR TANT 10% 4.7UF
C2002	2311049A72	CAP TANT CHIP 10.0UF 10% 10V
C2003	2113743K15	CHIP CAP, CER 0.1UF
C2004	2113743F18	CAP CHIP 2.2 UF 16V +80-20%
C2005	2113743F18	CAP CHIP 2.2 UF 16V +80-20%
C2006	2113743F18	CAP CHIP 2.2 UF 16V +80-20%
C2007	2113743E20	CAP CHIP. 10 UF 10%
C2008	2113743E20	CAP CHIP. 10 UF 10%
C2009	2113743E20	CAP CHIP. 10 UF 10%
C2010	2113743E20	CAP CHIP. 10 UF 10%
C2011	2113743E20	CAP CHIP. 10 UF 10%
C2012	NOT PLACED	GCAM DUMMY PART NUMBER
C2013	2113743E20	CAP CHIP. 10 UF 10%
C2014	2113743E20	CAP CHIP. 10 UF 10%
C2015	2113743E20	CAP CHIP. 10 UF 10%
C2016	2113743E20	CAP CHIP. 10 UF 10%
C2017	2113743E20	CAP CHIP. 10 UF 10%
C2018	2113740F53	CAP CHIP REEL CL1 +/-30 120
C2019	2113740F53	CAP CHIP REEL CL1 +/-30 120
C2020	2113743E20	CAP CHIP. 10 UF 10%
C2021	2113741F25	CAP CHIP CL2 X7R REEL 1000
C2022	2113741F49	CAP CHIP CL2 X7R REEL 10000
C2023	2113741F49	CAP CHIP CL2 X7R REEL 10000

Circuit Ref.	Motorola Part No.	Description
C2024	2113741F49	CAP CHIP CL2 X7R REEL 10000
C2025	2113741F49	CAP CHIP CL2 X7R REEL 10000
C2026	2113741F49	CAP CHIP CL2 X7R REEL 10000
C2027	2113741F49	CAP CHIP CL2 X7R REEL 10000
C2028	2113741F33	CAP CHIP CL2 X7R REEL 2200
C2029	2113740F53	CAP CHIP REEL CL1 +/-30 120
C2030	2113741F39	CAP CHIP CL2 XTR REEL 3900
C2031	NOT PLACED	GCAM DUMMY PART NUMBER
C2032	2113740F53	CAP CHIP REEL CL1 +/-30 120
C2033	2113740F53	CAP CHIP REEL CL1 +/-30 120
C2034	2113740F53	CAP CHIP REEL CL1 +/-30 120
C2035	2113740F53	CAP CHIP REEL CL1 +/-30 120
C2036	2113740F53	CAP CHIP REEL CL1 +/-30 120
C2037	2113740F53	CAP CHIP REEL CL1 +/-30 120
C2038	2113740F53	CAP CHIP REEL CL1 +/-30 120
C2039	2113740F53	CAP CHIP REEL CL1 +/-30 120
C2040	2113740F53	CAP CHIP REEL CL1 +/-30 120
C2041	2113740F53	CAP CHIP REEL CL1 +/-30 120
C2042	2113740F53	CAP CHIP REEL CL1 +/-30 120

Circuit Ref.	Motorola Part No.	Description
C2043	2113740L14	CAP CER CHIP 6.8PF +/-0.1PF
C2044	NOT PLACED	GCAM DUMMY PART NUMBER
C2045	2113740F53	CAP CHIP REEL CL1 +/-30 120
C2046	2113740F53	CAP CHIP REEL CL1 +/-30 120
C2047	2113740F53	CAP CHIP REEL CL1 +/-30 120
C2048	2113740F53	CAP CHIP REEL CL1 +/-30 120
C2049	NOT PLACED	GCAM DUMMY PART NUMBER
C2050	2113740F53	CAP CHIP REEL CL1 +/-30 120
C2051	2113740F59	CAP CHIP REEL CL1 +/-30 220
C2052	2113740F53	CAP CHIP REEL CL1 +/-30 120
C2053	NOT PLACED	GCAM DUMMY PART NUMBER
C2054	2113740L37	CAP 62.0 PF 50V 2.0%
C2055	2113740F35	CAP CHIP REEL CL1 +/-30 22
C2056	2113740F20	CAP CHIP REEL CL1 +/-30 5.1
C2057	2113740F20	CAP CHIP REEL CL1 +/-30 5.1
C2058	2113740F20	CAP CHIP REEL CL1 +/-30 5.1
C2059	2113740F20	CAP CHIP REEL CL1 +/-30 5.1
C2060	2113740F31	CAP CHIP REEL CL1 +/-30 15
C2061	2113740A31	CAP CHIP REEL CL1 +/-30 12
C2062	2113740F29	CAP CHIP REEL CL1 +/-30 12

Circuit Ref.	Motorola Part No.	Description
C2063	2113740L16	CAP CER CHIP 8.2 PF +/-0.1PF
C2064	2113740A23	CAP CHIP REEL CL1 +/-30 6.2
C2065	2113740F53	CAP CHIP REEL CL1 +/-30 120
C2066	2113740L03	CAP CER CHIP 2.4PF +/-0.1PF
C2067	2113740F20	CAP CHIP REEL CL1 +/-30 5.1
C2068	2113740F20	CAP CHIP REEL CL1 +/-30 5.1
C2069	2113740F05	CAP CHIP REEL CL1 +/-30 1.2
C2070	2113740L13	CAP CER CHIP 6.2 PF +/-0.1PF
C2071	2113740L13	CAP CER CHIP 6.2 PF +/-0.1PF
C2072	2113740L04	CAP CER CHIP 2.7 PF +/-0.1PF
C2073	2113740F03	CAP CHIP REEL CL1 +/-30 1.0
C2074	2109720D14	CAP CER CHIP LOW DIST 0.1UF
C2076	NOT PLACED	GCAM DUMMY PART NUMBER
C2078	0886629Z02	CAP,FILM,1UF,+10%,--10%,63V-D
C2129	2113740F53	CAP CHIP REEL CL1 +/-30 120
C2198	2113741F25	CAP CHIP CL2 X7R REEL 1000
C300	NOT PLACED	GCAM DUMMY PART NUMBER
C301	2311049A57	CAP TANT CHIP A/P 10UF 10% 16
C302	2113740F54	CAP CHIP REEL CL1 +/-30 130
C303	2113743K15	CHIP CAP, CER 0.1UF

Circuit Ref.	Motorola Part No.	Description
C304	2113743E20	CAP CHIP. 10 UF 10%
C305	2113743E20	CAP CHIP. 10 UF 10%
C306	2113743E20	CAP CHIP. 10 UF 10%
C307	2113743E20	CAP CHIP. 10 UF 10%
C308	2113743E20	CAP CHIP. 10 UF 10%
C309	2113743E20	CAP CHIP. 10 UF 10%
C310	2113743E20	CAP CHIP. 10 UF 10%
C311	2113743E20	CAP CHIP. 10 UF 10%
C312	2113743E20	CAP CHIP. 10 UF 10%
C313	2113743E20	CAP CHIP. 10 UF 10%
C314	2113743E20	CAP CHIP. 10 UF 10%
C315	2113743E20	CAP CHIP. 10 UF 10%
C316	2113743E20	CAP CHIP. 10 UF 10%
C317	2113743E20	CAP CHIP. 10 UF 10%
C318	2113743E20	CAP CHIP. 10 UF 10%
C319	2113743E20	CAP CHIP. 10 UF 10%
C320	2113743E20	CAP CHIP. 10 UF 10%
C321	2113740F53	CAP CHIP REEL CL1 +/-30 120
C322	2113741F41	CAP CHIP CL2 X7R REEL 4700
C323	2113741F25	CAP CHIP CL2 X7R REEL 1000
C324	2113740F53	CAP CHIP REEL CL1 +/-30 120
C325	2113740F53	CAP CHIP REEL CL1 +/-30 120
C326	2113743E07	CER CHIP CAP .022UF
C327	2113741F13	CAP CHIP CL2 X7R REEL 330
C328	2113740F42	CAP CHIP REEL CL1 +/-30 43
C329	2113740L31	CAP 36.0 PF 50V 2.0 %
C330	2113740L18	CAP CER CHIP 10.0 PF +/- .25PF

Circuit Ref.	Motorola Part No.	Description
C331	2113740L18	CAP CER CHIP 10.0 PF +/- .25PF
C332	2113740L18	CAP CER CHIP 10.0 PF +/- .25PF
C333	2113740L20	CAP 12.0 PF 50V 2.0 %
C334	2113740L25	CAP CER CHIP 20.0 PF +/- .25PF
C335	2113740L18	CAP CER CHIP 10.0 PF +/- .25PF
C336	2113740L17	CAP CER CHIP 9.1 PF+- 0.1PF
C337	2113740L14	CAP CER CHIP 6.8PF +- 0.1PF
C338	2113740L18	CAP CER CHIP 10.0 PF +/- .25PF
C339	2113740L03	CAP CER CHIP 2.4PF +- 0.1PF
C340	2113740L03	CAP CER CHIP 2.4PF +- 0.1PF
C341	2113740F19	CAP CHIP REEL CL1 +/-30 4.7
C342	2113740F19	CAP CHIP REEL CL1 +/-30 4.7
C343	2113740L07	CAP CER CHIP 3.6PF +- 0.1PF
C344	2113740L07	CAP CER CHIP 3.6PF +- 0.1PF
C345	2113740L08	CAP CER CHIP 3.9 PF+/- 0.1PF
C346	2113740L09	CAP CER CHIP 4.3 PF +- 0.1PF
C347	2113740L07	CAP CER CHIP 3.6PF +- 0.1PF
C348	2113740L06	CAP CER CHIP 3.3 PF+/- 0.1PF
C349	2113740F53	CAP CHIP REEL CL1 +/-30 120
C350	2113740F53	CAP CHIP REEL CL1 +/-30 120

Circuit Ref.	Motorola Part No.	Description
C351	2113743E20	CAP CHIP. 10 UF 10%
C352	0662057A05	CHIP RES 15 OHMS 5%
C353	NOT PLACED	GCAM DUMMY PART NUMBER
C354	2113740F49	CAP CHIP REEL CL1 +/-30 82
C355	NOT PLACED	GCAM DUMMY PART NUMBER
C356	2113740L22	CAP 15.0 PF 50V 2.0 %
C357	NOT PLACED	GCAM DUMMY PART NUMBER
C358	NOT PLACED	GCAM DUMMY PART NUMBER
C359	2113740F39	CAP CHIP REEL CL1 +/-30 33
C360	2113740F38	CAP CHIP REEL CL1 +/-30 30
C361	NOT PLACED	GCAM DUMMY PART NUMBER
C362	2113740F33	CAP CHIP REEL CL1 +/-30 18
C364	NOT PLACED	GCAM DUMMY PART NUMBER
C365	NOT PLACED	GCAM DUMMY PART NUMBER
C366	2113740L18	CAP CER CHIP 10.0 PF +/- .25PF
C367	2113740L16	CAP CER CHIP 8.2 PF+- 0.1PF
C368	2113740F25	CAP CHIP REEL CL1+/-30 8.2
C369	2113740F25	CAP CHIP REEL CL1+/-30 8.2
C370	2113740L27	CAP 24.0 PF 50V 2.0 %
C371	NOT PLACED	GCAM DUMMY PART NUMBER
C400	2113740F53	CAP CHIP REEL CL1 +/-30 120

Circuit Ref.	Motorola Part No.	Description
C401	2113743K15	CHIP CAP, CER 0.1UF
C402	NOT PLACED	GCAM DUMMY PART NUMBER
C403	2113743K15	CHIP CAP, CER 0.1UF
C404	2113743K15	CHIP CAP, CER 0.1UF
C405	2113743K15	CHIP CAP, CER 0.1UF
C406	2113743K15	CHIP CAP, CER 0.1UF
C407	2113743K15	CHIP CAP, CER 0.1UF
C408	2113743K15	CHIP CAP, CER 0.1UF
C410	2113743K15	CHIP CAP, CER 0.1UF
C411	NOT PLACED	GCAM DUMMY PART NUMBER
C412	2113740F53	CAP CHIP REEL CL1 +/-30 120
C413	2113740F53	CAP CHIP REEL CL1 +/-30 120
C414	2113740F53	CAP CHIP REEL CL1 +/-30 120
C415	2113740F53	CAP CHIP REEL CL1 +/-30 120
C416	2113740F53	CAP CHIP REEL CL1 +/-30 120
C417	2113740F53	CAP CHIP REEL CL1 +/-30 120
C418	2113740F53	CAP CHIP REEL CL1 +/-30 120
C421	2113743E07	CER CHIP CAP .022UF
C422	2113740F53	CAP CHIP REEL CL1 +/-30 120
C423	2113743K15	CHIP CAP, CER 0.1UF
C490	NOT PLACED	GCAM DUMMY PART NUMBER
C5000	2113741F25	CAP CHIP CL2 X7R REEL 1000
C5001	2389289U01	10UF 50V 20% ALUMINUM SMD

Circuit Ref.	Motorola Part No.	Description
C5002	2311049A99	CAP TANT CHIP 47 UF 10V 20%
C5003	2311049A99	CAP TANT CHIP 47 UF 10V 20%
C5004	NOT PLACED	GCAM DUMMY PART NUMBER
C5005	2360567A03	CAP TANTALUM
C5006	2311049A57	CAP TANT CHIP A/P 10UF 10% 16
C5007	2311049A99	CAP TANT CHIP 47 UF 10V 20%
C5008	2311049A57	CAP TANT CHIP A/P 10UF 10% 16
C5009	2311049A57	CAP TANT CHIP A/P 10UF 10% 16
C5010	2311049A57	CAP TANT CHIP A/P 10UF 10% 16
C5011	2311049A57	CAP TANT CHIP A/P 10UF 10% 16
C5012	2311049A56	CAP TAN CHIP A/P 4.7 20 10
C5013	2113928P04	CAP CER CHIP 1.0UF 20% 6.3V
C5014	NOT PLACED	GCAM DUMMY PART NUMBER
C5015	2113743K15	CHIP CAP, CER 0.1UF
C5016	2113743K15	CHIP CAP, CER 0.1UF
C5017	2113743K15	CHIP CAP, CER 0.1UF
C5018	2113743K15	CHIP CAP, CER 0.1UF
C5019	2113743K15	CHIP CAP, CER 0.1UF
C5020	2113743K15	CHIP CAP, CER 0.1UF
C5021	2113741M69	CAP CHIP CLS2 100000 PF 20V 1
C5022	2113743K15	CHIP CAP, CER 0.1UF
C5023	2113743K15	CHIP CAP, CER 0.1UF
C5024	2113743K15	CHIP CAP, CER 0.1UF
C5025	2113743K15	CHIP CAP, CER 0.1UF

Circuit Ref.	Motorola Part No.	Description
C5026	2113743K15	CHIP CAP, CER 0.1UF
C5027	2113743K15	CHIP CAP, CER 0.1UF
C5028	2113743K15	CHIP CAP, CER 0.1UF
C5029	2113743K15	CHIP CAP, CER 0.1UF
C5030	2113743K15	CHIP CAP, CER 0.1UF
C5031	2113743K15	CHIP CAP, CER 0.1UF
C5032	2113743K15	CHIP CAP, CER 0.1UF
C5033	2113743K15	CHIP CAP, CER 0.1UF
C5034	2113743K15	CHIP CAP, CER 0.1UF
C5035	2113743K15	CHIP CAP, CER 0.1UF
C5036	2113743K15	CHIP CAP, CER 0.1UF
C5037	2113743K15	CHIP CAP, CER 0.1UF
C5038	2113743K15	CHIP CAP, CER 0.1UF
C5039	NOT PLACED	GCAM DUMMY PART NUMBER
C5040	NOT PLACED	GCAM DUMMY PART NUMBER
C5041	2113743F18	CAP CHIP 2.2 UF 16V +80-20%
C5042	2113743F16	CAP CHIP 1.0UF 16V+80-20%
C5043	2113743F16	CAP CHIP 1.0UF 16V+80-20%
C5044	2113928C04	CAP CER CHIP 4.7UF 6.3V10%080
C5045	2113743F16	CAP CHIP 1.0UF 16V+80-20%
C5046	2113743E20	CAP CHIP. 10 UF 10%
C5047	2113743E20	CAP CHIP. 10 UF 10%
C5048	2113743E20	CAP CHIP. 10 UF 10%
C5049	2113743E20	CAP CHIP. 10 UF 10%
C5050	2113743E20	CAP CHIP. 10 UF 10%
C5051	2113743E20	CAP CHIP. 10 UF 10% (CM160)
C5052	2113743E20	CAP CHIP. 10 UF 10%

Circuit Ref.	Motorola Part No.	Description
C5053	2113743E20	CAP CHIP. 10 UF 10% (CM160)
C5054	2113743E20	CAP CHIP. 10 UF 10% (CM160)
C5055	2113928C04	CAP CER CHIP 4.7UF 6.3V10%080
C5056	2113741M69	CAP CHIP CLS2 100000 PF 20V 1 (CM160)
C5057	2113928C04	CAP CER CHIP 4.7UF 6.3V10%080
C5058	NOT PLACED	GCAM DUMMY PART NUMBER
C5059	2113743E07	CER CHIP CAP .022UF
C5060	2113741M69	CAP CHIP CLS2 100000 PF 20V 1
C5061	2113741M69	CAP CHIP CLS2 100000 PF 20V 1
C5062	2113741M69	CAP CHIP CLS2 100000 PF 20V 1
C5063	2113741M69	CAP CHIP CLS2 100000 PF 20V 1
C5064	2113740F53	CAP CHIP REEL CL1 +/-30 120
C5065	2113740F53	CAP CHIP REEL CL1 +/-30 120
C5066	2113740F53	CAP CHIP REEL CL1 +/-30 120
C5067	2113741F25	CAP CHIP CL2 X7R REEL 1000
C5068	2113740F53	CAP CHIP REEL CL1 +/-30 120
C5069	2113740F53	CAP CHIP REEL CL1 +/-30 120
C5070	2113740F53	CAP CHIP REEL CL1 +/-30 120
C5071	2113740F53	CAP CHIP REEL CL1 +/-30 120
C5072	2113740F53	CAP CHIP REEL CL1 +/-30 120

Circuit Ref.	Motorola Part No.	Description
C5073	2113740F53	CAP CHIP REEL CL1 +/-30 120
C5074	2113740F53	CAP CHIP REEL CL1 +/-30 120
C5075	NOT PLACED	GCAM DUMMY PART NUMBER
C5076	2113740F53	CAP CHIP REEL CL1 +/-30 120
C5077	2113740F53	CAP CHIP REEL CL1 +/-30 120
C5078	2113741F25	CAP CHIP CL2 X7R REEL 1000
C5079	2113740F53	CAP CHIP REEL CL1 +/-30 120
C5080	2113740F53	CAP CHIP REEL CL1 +/-30 120
C5081	2113740F53	CAP CHIP REEL CL1 +/-30 120
C5082	2113740F53	CAP CHIP REEL CL1 +/-30 120
C5083	2113740F53	CAP CHIP REEL CL1 +/-30 120
C5084	2113740F53	CAP CHIP REEL CL1 +/-30 120
C5085	2113741A53	CAP CHIP CL2 X7R REEL 22000
C5086	2113741A53	CAP CHIP CL2 X7R REEL 22000
C5087	2113740F53	CAP CHIP REEL CL1 +/-30 120
C5088	2113740F49	CAP CHIP REEL CL1 +/-30 82
C5089	2113740F49	CAP CHIP REEL CL1 +/-30 82
C5090	2113740F49	CAP CHIP REEL CL1 +/-30 82
C5091	2113740F49	CAP CHIP REEL CL1 +/-30 82

Circuit Ref.	Motorola Part No.	Description	Circuit Ref.	Motorola Part No.	Description	Circuit Ref.	Motorola Part No.	Description	Circuit Ref.	Motorola Part No.	Description
C5092	2113740F59	CAP CHIP REEL CL1 +/-30 220	C5118	NOT PLACED	GCAM DUMMY PART NUMBER	C618	2113740F41	CAP CHIP REEL CL1 +/-30 39	CR301	4880154K03	SOT MMBD353 RH DIODE DUAL SCH
C5094	2113740F59	CAP CHIP REEL CL1 +/-30 220	C5119	2113743H14	CAP CHIP 10.0 UF 16V +80-20%	C619	NOT PLACED	GCAM DUMMY PART NUMBER	D100	NOT PLACED	GCAM DUMMY PART NUMBER
C5095	2113740F59	CAP CHIP REEL CL1 +/-30 220	C5120	NOT PLACED	GCAM DUMMY PART NUMBER	C620	2113740F41	CAP CHIP REEL CL1 +/-30 39	D101	NOT PLACED	GCAM DUMMY PART NUMBER
C5096	2113740F59	CAP CHIP REEL CL1 +/-30 220	C602	2113740F41	CAP CHIP REEL CL1 +/-30 39	C621	2113740F41	CAP CHIP REEL CL1 +/-30 39	D102	4813833C02	DIODE DUAL 70V '5B' COMM CATH
C5097	2113740F59	CAP CHIP REEL CL1 +/-30 220	C603	2113740F41	CAP CHIP REEL CL1 +/-30 39	C622	2113740F41	CAP CHIP REEL CL1 +/-30 39	D103	4802482J02	PIN DIODE SMD
C5098	2113740F59	CAP CHIP REEL CL1 +/-30 220	C604	2113740F41	CAP CHIP REEL CL1 +/-30 39	C623	2113740F41	CAP CHIP REEL CL1 +/-30 39	D104	4802482J02	PIN DIODE SMD
C5099	2113740F59	CAP CHIP REEL CL1 +/-30 220	C605	2113740F41	CAP CHIP REEL CL1 +/-30 39	C624	2113740F41	CAP CHIP REEL CL1 +/-30 39	D105	4805218N57	DIODE DUAL
C5100	2113740F59	CAP CHIP REEL CL1 +/-30 220	C606	2113740F41	CAP CHIP REEL CL1 +/-30 39	C625	2113740F41	CAP CHIP REEL CL1 +/-30 39	D106	4805218N57	DIODE DUAL
C5101	2113741F25	CAP CHIP CL2 X7R REEL 1000 (CM160)	C607	2113740F41	CAP CHIP REEL CL1 +/-30 39	C626	2113740F41	CAP CHIP REEL CL1 +/-30 39	D107	4805218N57	DIODE DUAL
C5102	2113743E20	CAP CHIP. 10 UF 10% (CM160)	C608	NOT PLACED	GCAM DUMMY PART NUMBER	C627	2113740F41	CAP CHIP REEL CL1 +/-30 39	D108	4805218N57	DIODE DUAL
C5103	2113743K15	CHIP CAP, CER 0.1UF (CM160)	C609	NOT PLACED	GCAM DUMMY PART NUMBER	C628	2113740F41	CAP CHIP REEL CL1 +/-30 39	D200	4802233J09	DIODE TRIPLE SOT25-RH
C5104	NOT PLACED	GCAM DUMMY PART NUMBER	C610	2113740F41	CAP CHIP REEL CL1 +/-30 39	C629	2113740F41	CAP CHIP REEL CL1 +/-30 39	D201	4802233J09	DIODE TRIPLE SOT25-RH
C5110	2113741F25	CAP CHIP CL2 X7R REEL 1000	C611	2113740F41	CAP CHIP REEL CL1 +/-30 39	C630	2113740F41	CAP CHIP REEL CL1 +/-30 39	D202	4862824C03	DIODE VARACTOR
C5111	2113741F25	CAP CHIP CL2 X7R REEL 1000	C612	2113740F41	CAP CHIP REEL CL1 +/-30 39	C631	2113740F41	CAP CHIP REEL CL1 +/-30 39	D203	4805649Q13	DIODE VCTR ISV 228
C5113	NOT PLACED	GCAM DUMMY PART NUMBER	C613	2113740F41	CAP CHIP REEL CL1 +/-30 39	C632	2113740F41	CAP CHIP REEL CL1 +/-30 39	D204	4805649Q13	DIODE VCTR ISV 228
C5114	NOT PLACED	GCAM DUMMY PART NUMBER	C614	2113740F41	CAP CHIP REEL CL1 +/-30 39	C633	2113740F41	CAP CHIP REEL CL1 +/-30 39	D205	4862824C01	DIODE VARACTOR
C5115	NOT PLACED	GCAM DUMMY PART NUMBER	C615	2113740F41	CAP CHIP REEL CL1 +/-30 39	C662	2113740F41	CAP CHIP REEL CL1 +/-30 39	D301	4802245J97	Band Switchind Diode, Rohm DA
C5116	NOT PLACED	GCAM DUMMY PART NUMBER	C616	2113740F41	CAP CHIP REEL CL1 +/-30 39	C678	2113741M69	CAP CHIP CLS2 100000 PF 20V 1	D302	4802245J97	Band Switchind Diode, Rohm DA
C5117	NOT PLACED	GCAM DUMMY PART NUMBER	C617	2113740F41	CAP CHIP REEL CL1 +/-30 39	CR300	4880154K03	SOT MMBD353 RH DIODE DUAL SCH	D303	4802245J97	Band Switchind Diode, Rohm DA
									D304	4802245J97	Band Switchind Diode, Rohm DA
									D305	4880142L01	SOT MMBV109 RH
									D400	4813833C07	DIODE DUAL 100V '5C' SERIES
									D401	4813833C02	DIODE DUAL 70V '5B' COMM CATH
									D402	4809948D42	DIODE SCHOTTKY RB751V-40

Circuit Ref.	Motorola Part No.	Description
D500	4813833C02	DIODE DUAL 70V '5B' COMM CATH
D501	NOT PLACED	GCAM DUMMY PART NUMBER
D502	4813825A23	DIODE, DISCRETE SPECIALS VAR&
D511	4813833C02	DIODE DUAL 70V '5B' COMM CATH
D513	4813833C02	DIODE DUAL 70V '5B' COMM CATH
FL300	9180022M11	XTAL FILTER 44.85MHZ
FL301	9180468V06	SMD455KHZ 4 ELEMENT CER FLTR
FL302	9180468V04	SMD455KHZ 4 ELEMENT CER FLTR
FL303	9180469V03	SMD455KHZ 6 ELEMENT CER FLTR
FL304	9180469V06	SMD455KHZ 6 ELEMENT CER FLTR
J11	2889309U01	MINI-UHF PCB R.A
J2	0989241U02	FLEX 20PIN 1MM TOP NON ZIF
J3	0986615Z01	CONN,ZIF,F,28CONT,,TIN,,, CBL (CM160)
L100	7686135U02	FLTR,EMI
L101	2462587T30	IND CHIP 1000NH 5% LOW PRO
L102	2462587T30	IND CHIP 1000NH 5% LOW PRO
L103	2462587T30	IND CHIP 1000NH 5% LOW PRO
L104	2462587N50	CHIP IND 56 NH 5%
L105	2462587N44	CHIP IND 18 NH 5%
L107	2460591B04	COIL AIR WOUND INDUC 11.03
L108	2462587T22	IND. CHIP 390NH 5% LOW PRO
L111	2460592A01	COIL AW 2 TURN 17 NH

Circuit Ref.	Motorola Part No.	Description
L113	2460592A01	COIL AW 2 TURN 17 NH
L114	2485873L01	ENCAPSULATED AIR WOUND COIL
L115	2460592A01	COIL AW 2 TURN 17 NH
L117	7686135U02	FLTR,EMI
L118	7686135U02	FLTR,EMI
L119	7686135U02	FLTR,EMI
L120	7686135U02	FLTR,EMI
L121	7686135U02	FLTR,EMI
L122	2460591C23	COIL AIR WOUND INDUC 13.85
L124	7686135U02	FLTR,EMI
L125	2460592A01	COIL AW 2 TURN 17 NH
L126	2460591B77	COIL AIR WOUND INDUC 13.90
L127	2460591B77	COIL AIR WOUND INDUC 13.90
L128	2460592A01	COIL AW 2 TURN 17 NH
L130	2462587T22	IND. CHIP 390NH 5% LOW PRO
L200	2462587Q42	IND CHIP 390NH 10%
L201	2462587V44	IND CHIP 680 NH 10%
L202	2462587V44	IND CHIP 680 NH 10%
L203	2462587V36	CHIP IND 150NH 5% 0805
L204	2462587V36	CHIP IND 150NH 5% 0805
L205	2462587Q47	IND CHIP 1000 NH 10%
L206	2484562T11	COIL SURF MNT AIR WOUND
L207	2413923C12	IND CHIP 7.8 NH 2%
L208	2413926N24	IND CER CHIP 100.0 NH 5%
L209	2413926N24	IND CER CHIP 100.0 NH 5%
L210	2413926H20	IND CHIP 47.0 NH 5%
L211	2413926N24	IND CER CHIP 100.0 NH 5%
L212	2413926N18	IND CER CHIP 33.0 NH 5%

Circuit Ref.	Motorola Part No.	Description
L213	2413926N24	IND CER CHIP 100.0 NH 5%
L214	2413926H20	IND CHIP 47.0 NH 5%
L215	2413926H20	IND CHIP 47.0 NH 5%
L216	2462587N44	CHIP IND 18 NH 5%
L217	2462587Q42	IND CHIP 390NH 10%
L300	2460591C35	COIL AIR WOUND INDUC 18.08
L301	2462587N55	CHIP IND 150 NH 5%
L302	2462587N55	CHIP IND 150 NH 5%
L303	2462587X69	IND CHIP LO-PRO 1200 NH 5%
L304	2462587N55	CHIP IND 150 NH 5%
L305	2483411T74	INDUCTOR CHIP SHIELDED
L306	2413926K32	IND CER CHIP 560.0 NH 5%
L307	2460591C35	COIL AIR WOUND INDUC 18.08
L308	2460591C35	COIL AIR WOUND INDUC 18.08
L309	2460591C35	COIL AIR WOUND INDUC 18.08
L310	2460591C35	COIL AIR WOUND INDUC 18.08
L311	2460591C35	COIL AIR WOUND INDUC 18.08
L312	2460591C35	COIL AIR WOUND INDUC 18.08
L313	2460591C35	COIL AIR WOUND INDUC 18.08
L314	2460591C35	COIL AIR WOUND INDUC 18.08
L315	NOT PLACED	GCAM DUMMY PART NUMBER
L500	7686135U02	FLTR,EMI
L501	7686135U02	FLTR,EMI
L502	7686135U02	FLTR,EMI
M100	2680499Z01	HEAT SPREADER

Circuit Ref.	Motorola Part No.	Description
M101	3980686Z01	CONTACT (ANTENNA)
M102	3980686Z01	CONTACT (ANTENNA)
M105	7588823L03	PAD GROUND LCD
M106	7588823L03	PAD GROUND LCD
M107	7588823L03	PAD GROUND LCD
M108	7588823L04	PAD GROUND LCD
M109	7588823L04	PAD GROUND LCD
M110	7588823L04	PAD GROUND LCD
M9	0289511U01	NUTS
P1	2804503J01	CONNECTOR,ACCY 16 PIN
P2	NOT PLACED	GCAM DUMMY PART NUMBER
PCB	8486577Z01	Main PC Board, UHF Band 2 40W
Q100	4813828C32	TSTR UHF 70W 12.5V LD MOS
Q101	4813824A10	TSTR NPN 40V .2A GEN PURP
Q102	4813824A10	TSTR NPN 40V .2A GEN PURP
Q103	4813824A06	XSTR NPN 30V DARLINGTON
Q104	4813824A10	TSTR NPN 40V .2A GEN PURP
Q105	4886212B01	LD MOS PWR TSTR MRF1518
Q106	4805128M27	SOT TRANS
Q107	4813824A10	TSTR NPN 40V .2A GEN PURP
Q108	4813824A10	TSTR NPN 40V .2A GEN PURP
Q200	4802245J95	BJT, NPN TRANSISTOR
Q201	4809939C04	TSTR DUAL PNP/NPN UMC3
Q300	4809940E02	TSTR DIG NPN DTC114YE

Circuit Ref.	Motorola Part No.	Description
Q301	4813824A17	XSTR PNP40V .2A GENPB=100-300
Q302	4813824A10	TSTR NPN 40V .2A GEN PURP
Q303	4802245J95	BJT, NPN TRANSISTOR
Q304	4809939C04	TSTR DUAL PNP/NPN UMC3
Q305	4802197J95	RF TRANSISTOR PBR941
Q306	4813824A17	XSTR PNP40V .2A GENPB=100-300
Q400	4809940E02	TSTR DIG NPN DTC114YE
Q401	4880141L03	QSTR PNP SOT23 LO PROFILE TAP
Q403	4809940E02	TSTR DIG NPN DTC114YE
Q404	4809940E02	TSTR DIG NPN DTC114YE
Q405	4809940E02	TSTR DIG NPN DTC114YE
Q407	4809940E02	TSTR DIG NPN DTC114YE
Q408	4880048M01	TSTR NPN DIG 47K/47K
Q409	4880048M01	TSTR NPN DIG 47K/47K
Q410	4880048M01	TSTR NPN DIG 47K/47K
Q411	4880048M01	TSTR NPN DIG 47K/47K
Q412	4880048M01	TSTR NPN DIG 47K/47K
Q413	4809940E02	TSTR DIG NPN DTC114YE
Q414	4809940E02	TSTR DIG NPN DTC114YE
Q415	NOT PLACED	GCAM DUMMY PART NUMBER
Q416	4809940E02	TSTR DIG NPN DTC114YE
Q417	4813824A10	TSTR NPN 40V .2A GEN PURP
Q500	4813824A10	TSTR NPN 40V .2A GEN PURP
Q501	4809940E02	TSTR DIG NPN DTC114YE
Q502	4809940E02	TSTR DIG NPN DTC114YE
Q503	4813824A10	TSTR NPN 40V .2A GEN PURP

Circuit Ref.	Motorola Part No.	Description
Q504	4880048M01	TSTR NPN DIG 47K/47K
Q505	4813824A10	TSTR NPN 40V .2A GEN PURP
Q506	4813824A10	TSTR NPN 40V .2A GEN PURP
R101	1705603W01	RES SMT SHUNT
R103	0683962T51	RES CHIP 120 5-1
R104	0683962T51	RES CHIP 120 5-1
R105	0662057A41	CHIP RES 470 OHMS 5%
R106	0662057C35	CHIP RES 22 OHMS 5%
R107	0680194M18	RES 51 OHMS 5% 1W
R108	0680194M18	RES 51 OHMS 5% 1W
R109	0662057A14	RES CHIP 36 OHM 5 1/8W
R110	0662057A49	CHIP RES 1000 OHMS 5%
R111	0662057A49	CHIP RES 1000 OHMS 5%
R112	0662057B05	CHIP RES 200K OHMS 5%
R113	0662057A73	CHIP RES 10K OHMS 5%
R114	0662057A73	CHIP RES 10K OHMS 5%
R115	0662057A73	CHIP RES 10K OHMS 5%
R116	0662057A73	CHIP RES 10K OHMS 5%
R117	0662057P02	RES. CHIP 15K 1% 30X60
R118	0662057C51	CHIP RES 100 OHMS 5%
R119	0662057C51	CHIP RES 100 OHMS 5%
R120	0662057C51	CHIP RES 100 OHMS 5%
R121	0662057C51	CHIP RES 100 OHMS 5%
R122	0662057C19	CHIP RES 4.7 OHMS 5%
R126	0662057C01	CHIP RES 0 OHMS .050 OHMS
R127	0662057C01	CHIP RES 0 OHMS .050 OHMS
R128	0662057C01	CHIP RES 0 OHMS .050 OHMS
R129	0662057C01	CHIP RES 0 OHMS .050 OHMS

Circuit Ref.	Motorola Part No.	Description
R130	0662057B47	CHIP RES 0 OHMS +-.050 OHMS
R131	0662057A97	CHIP RES 100K OHMS 5%
R132	NOT PLACED	GCAM DUMMY PART NUMBER
R134	0662057A59	CHIP RES 2700 OHMS 5%
R135	0662057A86	CHIP RES 36K OHMS 5%
R136	0662057A86	CHIP RES 36K OHMS 5%
R137	0662057A87	CHIP RES 39K OHMS 5%
R138	0662057A86	CHIP RES 36K OHMS 5%
R139	0662057A87	CHIP RES 39K OHMS 5%
R140	0662057A79	CHIP RES 18K OHMS 5%
R141	0662057A81	CHIP RES 22K OHMS 5%
R142	0662057A81	CHIP RES 22K OHMS 5%
R143	0662057A79	CHIP RES 18K OHMS 5%
R144	0662057A81	CHIP RES 22K OHMS 5%
R145	0662057A81	CHIP RES 22K OHMS 5%
R146	0662057A81	CHIP RES 22K OHMS 5%
R147	0662057A59	CHIP RES 2700 OHMS 5%
R148	0662057A81	CHIP RES 22K OHMS 5%
R149	0662057A81	CHIP RES 22K OHMS 5%
R150	0662057A73	CHIP RES 10K OHMS 5%
R151	0662057A72	CHIP RES 9100 OHMS 5%
R152	0662057A25	CHIP RES 100 OHMS 5%
R153	0662057A83	CHIP RES 27K OHMS 5%
R155	0662057A83	CHIP RES 27K OHMS 5%
R156	0662057A73	CHIP RES 10K OHMS 5%
R157	0662057A91	CHIP RES 56K OHMS 5%
R158	NOT PLACED	GCAM DUMMY PART NUMBER
R159	NOT PLACED	GCAM DUMMY PART NUMBER
R160	0662057A61	CHIP RES 3300 OHMS 5%

Circuit Ref.	Motorola Part No.	Description
R161	0662057A61	CHIP RES 3300 OHMS 5%
R162	0662057A61	CHIP RES 3300 OHMS 5%
R163	0662057A61	CHIP RES 3300 OHMS 5%
R164	0662057A73	CHIP RES 10K OHMS 5%
R165	0662057A58	CHIP RES 2400 OHMS 5%
R166	NOT PLACED	GCAM DUMMY PART NUMBER
R167	0662057A57	CHIP RES 2200 OHMS 5%
R168	0662057A57	CHIP RES 2200 OHMS 5%
R169	NOT PLACED	GCAM DUMMY PART NUMBER
R170	0662057A42	CHIP RES 510 OHMS 5%
R171	0662057A43	CHIP RES 560 OHMS 5%
R172	0662057A41	CHIP RES 470 OHMS 5%
R173	0662057A29	CHIP RES 150 OHMS 5%
R174	0662057A29	CHIP RES 150 OHMS 5%
R175	0662057A43	CHIP RES 560 OHMS 5%
R176	NOT PLACED	GCAM DUMMY PART NUMBER
R177	NOT PLACED	GCAM DUMMY PART NUMBER
R178	0662057A18	CHIP RES 51 OHMS 5%
R179	0662057A18	CHIP RES 51 OHMS 5%
R180	0660082A89	RES CHIP 47K OHMS 1% 1/16W
R181	0660082A89	RES CHIP 47K OHMS 1% 1/16W
R182	0662057A73	CHIP RES 10K OHMS 5%
R183	0662057A25	CHIP RES 100 OHMS 5%
R184	0662057A59	CHIP RES 2700 OHMS 5%
R185	0662057A73	CHIP RES 10K OHMS 5%
R186	0662057A73	CHIP RES 10K OHMS 5%
R187	0662057A97	CHIP RES 100K OHMS 5%

Circuit Ref.	Motorola Part No.	Description
R188	NOT PLACED	GCAM DUMMY PART NUMBER
R189	0662057A97	CHIP RES 100K OHMS 5%
R190	0662057C35	CHIP RES 22 OHMS 5%
R191	0662057C35	CHIP RES 22 OHMS 5%
R192	0662057C35	CHIP RES 22 OHMS 5%
R193	NOT PLACED	GCAM DUMMY PART NUMBER
R194	NOT PLACED	GCAM DUMMY PART NUMBER
R195	NOT PLACED	GCAM DUMMY PART NUMBER
R196	0662057A97	CHIP RES 100K OHMS 5%
R197	0662057A59	CHIP RES 2700 OHMS 5%
R198	0662057A97	CHIP RES 100K OHMS 5%
R199	0662057A59	CHIP RES 2700 OHMS 5%
R200	0662057A97	CHIP RES 100K OHMS 5%
R201	0662057A73	CHIP RES 10K OHMS 5%
R202	NOT PLACED	GCAM DUMMY PART NUMBER
R203	0662057B47	CHIP RES 0 OHMS +-.050 OHMS
R204	NOT PLACED	GCAM DUMMY PART NUMBER
R205	NOT PLACED	GCAM DUMMY PART NUMBER
R206	0662057A99	CHIP RES 120K OHMS 5%
R207	0662057B02	CHIP RES 150K OHMS 5%
R208	0662057A97	CHIP RES 100K OHMS 5%
R209	0662057A97	CHIP RES 100K OHMS 5%
R210	NOT PLACED	GCAM DUMMY PART NUMBER
R211	0662057A69	RES CHIP 6800 OHM 5 1/8W
R212	0662057A89	CHIP RES 47K OHMS 5%
R213	0662057A65	CHIP RES 4700 OHMS 5%

Circuit Ref.	Motorola Part No.	Description
R214	0662057A65	CHIP RES 4700 OHMS 5%
R215	0662057A62	CHIP RES 3600 OHMS 5%
R216	0662057A59	CHIP RES 2700 OHMS 5%
R217	0662057A52	CHIP RES 1300OHMS 5%05
R218	0662057A49	CHIP RES 1000 OHMS 5%
R219	NOT PLACED	GCAM DUMMY PART NUMBER
R220	0662057A42	CHIP RES 510 OHMS 5%
R221	0662057A33	CHIP RES 220 OHMS 5%
R222	0662057A33	CHIP RES 220 OHMS 5%
R223	0662057A33	CHIP RES 220 OHMS 5%
R224	0662057A53	CHIP RES 1500 OHMS 5%
R225	0662057A29	CHIP RES 150 OHMS 5%
R226	0662057A29	CHIP RES 150 OHMS 5%
R227	0662057A23	CHIP RES 82 OHMS 5%
R228	0662057A25	CHIP RES 100 OHMS 5%
R229	0662057A25	CHIP RES 100 OHMS 5%
R230	0662057A22	CHIP RES 75 OHMS 5%
R231	0662057A18	CHIP RES 51 OHMS 5%
R232	0662057A17	RES CHIP 47 OHMS 5%
R233	0662057A17	RES CHIP 47 OHMS 5%
R234	0662057A15	CHIP RES 39 OHMS 5%
R235	0662057A07	CHIP RES 18 OHMS 5%
R300	0662057A73	CHIP RES 10K OHMS 5%
R301	0662057A41	CHIP RES 470 OHMS 5%
R302	0662057B47	CHIP RES 0 OHMS +-.050 OHMS
R303	0662057B47	CHIP RES 0 OHMS +-.050 OHMS
R304	0662057A85	CHIP RES 33K OHM 5%
R305	0662057A80	CHIP RES 20K OHMS 5%
R306	0662057A80	CHIP RES 20K OHMS 5%
R307	0662057A80	CHIP RES 20K OHMS 5%

Circuit Ref.	Motorola Part No.	Description
R308	0662057A80	CHIP RES 20K OHMS 5%
R309	0662057A77	CHIP RES 15K OHMS 5%
R310	0662057A77	CHIP RES 15K OHMS 5%
R311	NOT PLACED	GCAM DUMMY PART NUMBER
R312	0662057A76	CHIP RES 13K OHMS 5%
R313	0662057A75	CHIP RES 12K OHMS 5%
R314	0662057A75	CHIP RES 12K OHMS 5%
R315	0662057A75	CHIP RES 12K OHMS 5%
R316	0662057A75	CHIP RES 12K OHMS 5%
R317	0662057A75	CHIP RES 12K OHMS 5%
R318	0662057A75	CHIP RES 12K OHMS 5%
R319	0662057A75	CHIP RES 12K OHMS 5%
R320	0662057A73	CHIP RES 10K OHMS 5%
R321	0662057A71	CHIP RES 8200 OHMS 5%
R322	0662057A65	CHIP RES 4700 OHMS 5%
R323	0662057A65	CHIP RES 4700 OHMS 5%
R324	0662057A61	CHIP RES 3300 OHMS 5%
R325	0662057A61	CHIP RES 3300 OHMS 5%
R326	0662057A59	CHIP RES 2700 OHMS 5%
R327	0662057A58	CHIP RES 2400 OHMS 5%
R328	0662057A55	CHIP RES 1800 OHM 5%
R329	0662057A51	CHIP RES 1200 OHMS 5%
R330	0662057A47	CHIP RES 820 OHMS 5%
R331	0662057A25	CHIP RES 100 OHMS 5%
R332	0662057A45	CHIP RES 680 OHMS 5%
R333	0662057A43	CHIP RES 560 OHMS 5%
R334	0662057A40	CHIP RES 430 OHMS 5%
R335	0662057A39	CHIP RES 390 OHMS 5%
R336	0662057A33	CHIP RES 220 OHMS 5%
R337	0662057A25	CHIP RES 100 OHMS 5%
R338	0662057A25	CHIP RES 100 OHMS 5%

Circuit Ref.	Motorola Part No.	Description
R339	0662057A18	CHIP RES 51 OHMS 5%
R340	0662057A18	CHIP RES 51 OHMS 5%
R345	0662057A73	CHIP RES 10K OHMS 5%
R346	0662057A73	CHIP RES 10K OHMS 5%
R401	0662057C85	CHIP RES 2700 OHMS 5%
R402	0662057B47	CHIP RES 0 OHMS +-.050 OHMS
R403	0662057B47	CHIP RES 0 OHMS +-.050 OHMS
R404	0662057B47	CHIP RES 0 OHMS +-.050 OHMS
R405	0662057B47	CHIP RES 0 OHMS +-.050 OHMS
R406	0662057B47	CHIP RES 0 OHMS +-.050 OHMS
R407	0662057B47	CHIP RES 0 OHMS +-.050 OHMS
R414	0662057B47	CHIP RES 0 OHMS +-.050 OHMS
R415	NOT PLACED	GCAM DUMMY PART NUMBER
R421	0662057A33	CHIP RES 220 OHMS 5%
R422	0662057A73	CHIP RES 10K OHMS 5%
R423	NOT PLACED	GCAM DUMMY PART NUMBER
R424	NOT PLACED	GCAM DUMMY PART NUMBER
R425	0662057A97	CHIP RES 100K OHMS 5%
R426	0662057A97	CHIP RES 100K OHMS 5%
R427	NOT PLACED	GCAM DUMMY PART NUMBER
R428	0662057A97	CHIP RES 100K OHMS 5%
R429	0662057A97	CHIP RES 100K OHMS 5%
R430	0662057A87	CHIP RES 39K OHMS 5%
R431	NOT PLACED	GCAM DUMMY PART NUMBER

Circuit Ref.	Motorola Part No.	Description
R432	0662057A85	CHIP RES 33K OHM 5%
R433	0662057A85	CHIP RES 33K OHM 5%
R434	0662057A85	CHIP RES 33K OHM 5%
R435	0662057A85	CHIP RES 33K OHM 5%
R436	0662057A85	CHIP RES 33K OHM 5%
R438	0662057A73	CHIP RES 10K OHMS 5%
R439	0662057A73	CHIP RES 10K OHMS 5%
R440	0662057A73	CHIP RES 10K OHMS 5%
R441	0662057A73	CHIP RES 10K OHMS 5%
R442	0662057A73	CHIP RES 10K OHMS 5%
R443	0662057A61	CHIP RES 3300 OHMS 5%
R444	0662057A73	CHIP RES 10K OHMS 5%
R445	0662057A73	CHIP RES 10K OHMS 5%
R450	0662057A73	CHIP RES 10K OHMS 5%
R451	0662057A73	CHIP RES 10K OHMS 5%
R453	0662057A61	CHIP RES 3300 OHMS 5%
R454	0662057A61	CHIP RES 3300 OHMS 5%
R455	0662057A61	CHIP RES 3300 OHMS 5%
R456	0662057A61	CHIP RES 3300 OHMS 5%
R457	0662057A61	CHIP RES 3300 OHMS 5%
R458	0662057A61	CHIP RES 3300 OHMS 5%
R459	NOT PLACED	GCAM DUMMY PART NUMBER
R460	0662057A53	CHIP RES 1500 OHMS 5%
R461	0662057A33	CHIP RES 220 OHMS 5%
R462	0662057A18	CHIP RES 51 OHMS 5%
R463	0662057A73	CHIP RES 10K OHMS 5%
R466	NOT PLACED	GCAM DUMMY PART NUMBER
R467	NOT PLACED	GCAM DUMMY PART NUMBER
R468	NOT PLACED	GCAM DUMMY PART NUMBER

Circuit Ref.	Motorola Part No.	Description
R469	NOT PLACED	GCAM DUMMY PART NUMBER
R470	NOT PLACED	GCAM DUMMY PART NUMBER
R471	0662057A01	CHIP RES 10 OHMS 5%
R472	NOT PLACED	GCAM DUMMY PART NUMBER
R473	NOT PLACED	GCAM DUMMY PART NUMBER
R5000	0662057B47	CHIP RES 0 OHMS +/-0.050 OHMS
R5001	0662057T68	RES CHIP 1.0K 1% 30*60
R5002	0662057C01	CHIP RES 0 OHMS .050 OHMS (CM160)
R5008	0662057B47	CHIP RES 0 OHMS +/-0.050 OHMS
R5009	0662057B47	CHIP RES 0 OHMS +/-0.050 OHMS
R5010	0662057B47	CHIP RES 0 OHMS +/-0.050 OHMS
R5011	NOT PLACED	GCAM DUMMY PART NUMBER
R5013	NOT PLACED	GCAM DUMMY PART NUMBER
R5014	0662057B47	CHIP RES 0 OHMS +/-0.050 OHMS
R5016	NOT PLACED	GCAM DUMMY PART NUMBER
R5017	0609887C05	RES CHIP 1.5 OHM 1/2W 2010
R5018	0609887C05	RES CHIP 1.5 OHM 1/2W 2010
R5019	0662057B05	CHIP RES 200K OHMS 5%
R5020	0662057B02	CHIP RES 150K OHMS 5%
R5021	0662057A97	CHIP RES 100K OHMS 5%
R5022	0662057A97	CHIP RES 100K OHMS 5%
R5023	0662057A97	CHIP RES 100K OHMS 5%

Circuit Ref.	Motorola Part No.	Description
R5024	0662057A97	CHIP RES 100K OHMS 5% (CM160)
R5025	0662057A97	CHIP RES 100K OHMS 5%
R5026	0662057A85	CHIP RES 33K OHM 5%
R5027	0662057B08	CHIP RES 270K OHMS 5%
R5028	0662057A97	CHIP RES 100K OHMS 5%
R5029	0662057A97	CHIP RES 100K OHMS 5%
R5030	0662057A85	CHIP RES 33K OHM 5%
R5031	0662057A92	CHIP RES 62K OHMS 5%
R5032	0662057A89	CHIP RES 47K OHMS 5%
R5033	0662057A89	CHIP RES 47K OHMS 5%
R5034	0662057A86	CHIP RES 36K OHMS 5%
R5035	0662057A89	CHIP RES 47K OHMS 5%
R5036	0662057A89	CHIP RES 47K OHMS 5%
R5037	0662057A73	CHIP RES 10K OHMS 5%
R5038	0662057A85	CHIP RES 33K OHM 5%
R5039	0662057A97	CHIP RES 100K OHMS 5%
R5040	0662057A84	CHIP RES 30K OHMS 5%
R5041	0662057A82	CHIP RES 24K OHMS 5%
R5042	0662057A82	CHIP RES 24K OHMS 5%
R5043	0662057A82	CHIP RES 24K OHMS 5%
R5044	0662057A82	CHIP RES 24K OHMS 5%
R5045	0662057A85	CHIP RES 33K OHM 5%
R5046	0662057A82	CHIP RES 24K OHMS 5%
R5047	0662057B47	CHIP RES 0 OHMS +/-0.050 OHMS (CM160)
R5048	0662057A82	CHIP RES 24K OHMS 5%
R5049	0662057A77	CHIP RES 15K OHMS 5%
R5050	0662057A76	CHIP RES 13K OHMS 5%
R5051	0662057A75	CHIP RES 12K OHMS 5%
R5052	0662057A73	CHIP RES 10K OHMS 5%
R5053	0662057A73	CHIP RES 10K OHMS 5%
R5054	0662057A73	CHIP RES 10K OHMS 5%

Circuit Ref.	Motorola Part No.	Description
R5055	0662057A73	CHIP RES 10K OHMS 5%
R5056	0662057A73	CHIP RES 10K OHMS 5%
R5057	0662057A73	CHIP RES 10K OHMS 5%
R5058	NOT PLACED	GCAM DUMMY PART NUMBER
R5059	NOT PLACED	GCAM DUMMY PART NUMBER
R5060	0662057A73	CHIP RES 10K OHMS 5%
R5061	0662057A73	CHIP RES 10K OHMS 5%
R5062	0662057A73	CHIP RES 10K OHMS 5%
R5063	NOT PLACED	GCAM DUMMY PART NUMBER
R5064	NOT PLACED	GCAM DUMMY PART NUMBER
R5065	0662057A68	CHIP RES 6200 OHMS 5%
R5066	0662057A49	CHIP RES 1000 OHMS 5%
R5067	NOT PLACED	GCAM DUMMY PART NUMBER
R5068	NOT PLACED	GCAM DUMMY PART NUMBER
R5069	0662057A73	CHIP RES 10K OHMS 5%
R5070	0662057A57	CHIP RES 2200 OHMS 5%
R5071	0662057A57	CHIP RES 2200 OHMS 5%
R5072	0662057A65	CHIP RES 4700 OHMS 5%
R5073	0662057A49	CHIP RES 1000 OHMS 5%
R5074	0662057A49	CHIP RES 1000 OHMS 5%
R5075	0662057A42	CHIP RES 510 OHMS 5%
R5076	0662057A42	CHIP RES 510 OHMS 5%
R5077	0662057A36	CHIP RES 300 OHMS 5%
R5078	0662057A25	CHIP RES 100 OHMS 5%
R5079	0662057A25	CHIP RES 100 OHMS 5%
R5080	0662057A01	CHIP RES 10 OHMS 5%
R5081	0613952D78	CER CHIP RES 6340 OHM 1% 0603

Circuit Ref.	Motorola Part No.	Description
R5082	0662057A90	CHIP RES 51K OHMS 5%
R5083	0662057B08	CHIP RES 270K OHMS 5%
R5084	0662057B47	CHIP RES 0 OHMS +/-0.050 OHMS (CM160)
R5085	NOT PLACED	GCAM DUMMY PART NUMBER
R5086	0662057A43	CHIP RES 560 OHMS 5%
R5087	0662057A97	CHIP RES 100K OHMS 5%
R5088	0662057B47	CHIP RES 0 OHMS +/-0.050 OHMS
R5089	NOT PLACED	GCAM DUMMY PART NUMBER
R5092	NOT PLACED	GCAM DUMMY PART NUMBER
R5093	NOT PLACED	GCAM DUMMY PART NUMBER
R5094	NOT PLACED	GCAM DUMMY PART NUMBER
R5095	NOT PLACED	GCAM DUMMY PART NUMBER
R5096	NOT PLACED	GCAM DUMMY PART NUMBER
R5097	0662057B47	CHIP RES 0 OHMS +/-0.050 OHMS
R5098	NOT PLACED	GCAM DUMMY PART NUMBER
R5099	NOT PLACED	GCAM DUMMY PART NUMBER
R5100	NOT PLACED	GCAM DUMMY PART NUMBER
R5103	NOT PLACED	GCAM DUMMY PART NUMBER
R600	0662057C01	CHIP RES 0 OHMS .050 OHMS
R601	0611077A62	RES CHIP 330 5 1/8W
R602	0662057B47	CHIP RES 0 OHMS +/-0.050 OHMS

Circuit Ref.	Motorola Part No.	Description
R603	NOT PLACED	GCAM DUMMY PART NUMBER
R604	NOT PLACED	GCAM DUMMY PART NUMBER
R610	0662057C59	CHIP RES 220 OHMS 5%
R615	0662057A25	CHIP RES 100 OHMS 5%
RT100	0680361L01	THERMISTOR 47KOHM
S5010	1889288U01	POTENTIOMETER W/ SWITCH VOLUME
SH200	2689590U01	VCO SHIELD
SH201	2689589U01	VCO SHIELD
SH202	2689589U01	VCO SHIELD
SH300	2689591U01	MIXER SHIELD
SH301	2689593U01	FRONT ENA SHIELD
SH302	2689591U01	MIXER SHIELD
T300	2580541Z01	BALUN TRANSFORMER
T301	2580541Z01	BALUN TRANSFORMER
U100	5113818A01	IC LOW COST SING SPLY LM2904D
U101	5185130C65	IC VHF/UHF/800 MHZ LD MOS DRIV
U102	5113818A01	IC LOW COST SING SPLY LM2904D
U103	5113819A04	IC QD OP AMP GEN PURP MC3303D
U200	5185963A27	IC TESTED AT25016 48 PIN GFP
U201	5105750U54	IC PKG DIE VCO BUFFER
U300	5186144B01	FM IF IC SA616
U301	5109522E10	IC 3-INV LMOS TC7W04FU
U302	4808612Y05	CROSSOVER QUAD DIODE SMS3928-
U400	5102463J64	16KX8 SPI SERIAL EEPROM
U402	NOT PLACED	GCAM DUMMY PART NUMBER

Circuit Ref.	Motorola Part No.	Description
U403	5102226J56	68HC11FLO_PASS5 100P IN TQFP
U404	5189233U02	FLASH 2MEG AT49LV002N-70VI
U405	5113805A75	IC 8 BIT SER TO PAR/PAR HC595
U500	NOT PLACED	GCAM DUMMY PART NUMBER
U501	0104016J81	9V REGULATOR ASSEMBLY
U502	5102463J95	AUDIO PA TDA1519C
U503	5105469E65	IC VLTG REGLTR
U504	5185130C53	IC ASFIC_CMP_R1
U505	5113818A01	IC LOW COST SING SPLY LM2904D
U506	5113818A01	IC LOW COST SING SPLY LM2904D
U507	5113818A01	IC LOW COST SING SPLY LM2904D
U508	5113816A30	IC 3.3V LOW DROPOUT POS. REG.
U509	5113806A20	IC MUX/DEMUX TRIPLE 2-CHNL
U510	5104187K94	IC LP2986ILDV-3.3 VLTG REG
U514	4802393L66	MOSFET P-CH
U515	5162852A59	IC CMOS ANALOG SWITCH SPDT (CM160)
VR101	4813830A18	DIODE 6.8V 5% 225MWMMBZ5235B_
VR102	4813830A15	TSTR 5.6V 5% 20MA 225MW
VR400	NOT PLACED	GCAM DUMMY PART NUMBER
VR401	NOT PLACED	GCAM DUMMY PART NUMBER
VR402	4813830A09	DIODE 3.3V 5% 225MW MMBZ5226B
VR500	4813832C77	TRANS SUP. 24V HIGH PWR

Circuit Ref.	Motorola Part No.	Description
VR501	4813830A14	DIODE 5.1V 5% 225MW MMBZ5231B
VR502	NOT PLACED	GCAM DUMMY PART NUMBER
VR503	4813830G09	DIODE 3.3V 5% 'CK' 500MW_468
VR504	4813830G09	DIODE 3.3V 5% 'CK' 500MW_468
VR692	4813830A75	DIODE DUAL COM ANODE
VR693	4813830A77	DIODE DL ZENER TVS 33V 1.0A
VR694	4813830A75	DIODE DUAL COM ANODE
VR695	4813830A77	DIODE DL ZENER TVS 33V 1.0A
VR696	4813830A75	DIODE DUAL COM ANODE
VR697	4813830A75	DIODE DUAL COM ANODE
VR698	4813830A75	DIODE DUAL COM ANODE
VR699	4813830A75	DIODE DUAL COM ANODE
Y200	NOT PLACED	GCAM DUMMY PART NUMBER
Y201	4880114R06	CRYSTAL 16.8MHZ
Y300	9186145B02	CER.DISCR. CDBCA455CX36-TC
Y301	4880606B09	2ND OSC XTAL 44.395 MHZ
	0786637Z01	SPRT,REINFORCEMENT,CRS

